



DORMER VEILING 2023



HATARI AND FRIENDS



www.hatarifarming.co.za



BAIE WELKOM

Mag die goedheid en guns van God op jou boerdery rus.

Mag Hy jou familie en jou grond beskerm en mag jy altyd aan Hom alle eer gee.

Groete

Eksteens & Steenekamps

LOT 41 | T20-08



Met tweeling ooilammers nr 57 (100 dae, 51kg) en nr 58 (100 dae, 54kg), Vaar is Daan, weer dragtig met tweeling

LOT 39 | T20-20



T20-20 met ramlam nr 59, Vaar is Oorlog, weer dragtig met eenling

LOT 40 | T20-45



Met ooilam nr 462, Vaar is Daan, weer dragtig met tweeling

LOT 6 | T22-374



Top Gun - (Royal Show Reserve Senior Champion) Seun

LOT 37 | HE22-103



LOT 66 | HE22-113



LOT 38 | HE22-049



LOT 35 | HE22-072





GRAS KAROO
DORMERS

TOP 4

LOT 47 | DZ22-133



LOT 44 | DZ22-250



LOT 76 | DZ22-215



LOT 46 | DZ21-188



CHARITY LOTS



CHARITY LOT 1

POTCHEFSTROOM KOEKOEKS
1 HAAN EN 3 HENNE
DES. 2022 KUIKENS



CHARITY LOT 2

SWART ORPINGTONS
1 HAAN EN 3 HENNE
NOV. 2022 KUIKENS



CHARITY LOT 3

OPGESNYDE 32KG
A3 HATARI LAM



HATARI DORMER VEILING

BE-HUMAN16 September 2023



LOT 1 (M)

HE 220016



• Herd Book	SP
Birth date	2022-07-22
Age	1.1 years
Inbreeding	4.76%
Birth Stat.	1
Progeny	
None	

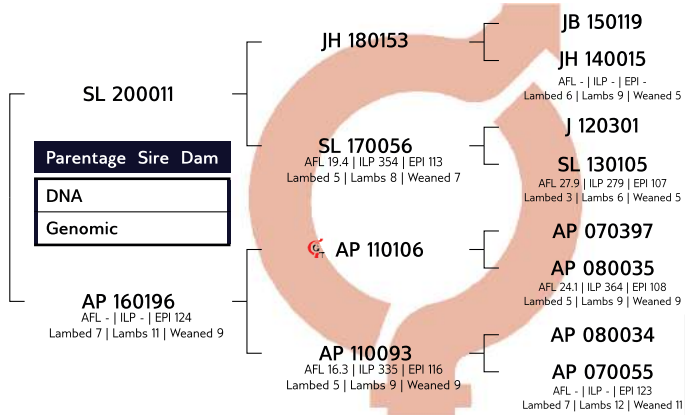

Growth			Reproduction			
Wn. Dir.	Wean Mat.	Post-Wn.	NLW	TWW	AFL	ILP
101	88	95	85	85	80	120
64%	53%	61%	39%	39%	37%	26%



EBV Analysis 2023-09-05

Logix Merit Index	89
Growth Index	98
Reproduction Index	79

EKSTEENS HATARI DORMER STUD
 Bloemfontein, Free State
 0825612917
 mariusjnr@diysuper.co.za



SELLER REMARKS:

LOT 2 (M)

HE 220019



• Herd Book	SP
Birth date	2022-07-22
Age	1.1 years
Inbreeding	5.34%
Birth Stat.	2
Progeny	
None	

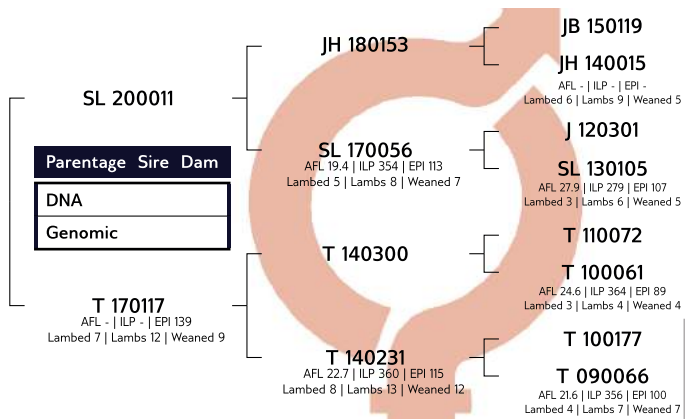

Growth			Reproduction			
Wn. Dir.	Wean Mat.	Post-Wn.	NLW	TWW	AFL	ILP
87	89	78	99	99	75	102
64%	53%	58%	39%	39%	37%	27%



EBV Analysis 2023-09-05

Logix Merit Index	82
Growth Index	85
Reproduction Index	85

EKSTEENS HATARI DORMER STUD
 Bloemfontein, Free State
 0825612917
 mariusjnr@diysuper.co.za



SELLER REMARKS:

LOT 3 (M)

HE 220020



• Herd Book	SP
Birth date	2022-07-20
Age	1.2 years
Inbreeding	9.67%
Birth Stat.	2
Progeny	
None	

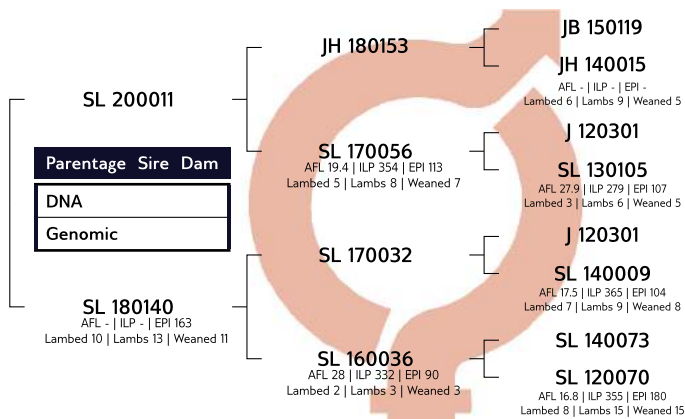

Growth			Reproduction			
Wn. Dir.	Wean Mat.	Post-Wn.	NLW	TWW	AFL	ILP
100	98	99	106	106	80	114
63%	51%	59%	35%	35%	32%	23%



EBV Analysis 2023-09-05

Logix Merit Index	103
Growth Index	102
Reproduction Index	102

EKSTEENS HATARI DORMER STUD
 Bloemfontein, Free State
 0825612917
 mariusjnr@diysuper.co.za



SELLER REMARKS:



HATARI DORMER VEILING

BE-HUMAN16 September 2023



LOT 4 (M)

HE 220025



Kuddeboek	SP
Geb. dtm	2022-07-20
Oud.	1.2 jaar
Inteling	6.99%
Geb. Status	3
Nageslag	
Geen	

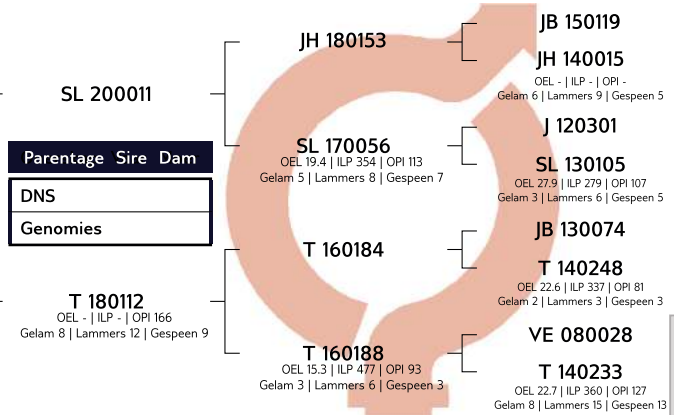

Growth			Reproduction			
Spn. Dir.	Spn. Mat.	Na-Spn.	GLS	TWW	OEL	ILP
102	103	102	106	106	90	113
64%	52%	60%	38%	38%	36%	26%



EBV Analise 2023-09-05

Logix Meriete Indeks	109
Groei Indeks	107
Reproduksie Indeks	109

EKSTEENS HATARI DORMER STUD
Bloemfontein, Free State
0825612917
mariusjnr@diysuper.co.za



VERKOPER OPMERKINGS:

LOT 5 (M)

HE 220048



Kuddeboek	SP
Geb. dtm	2022-07-20
Oud.	1.2 jaar
Inteling	5.75%
Geb. Status	2
Nageslag	
Geen	

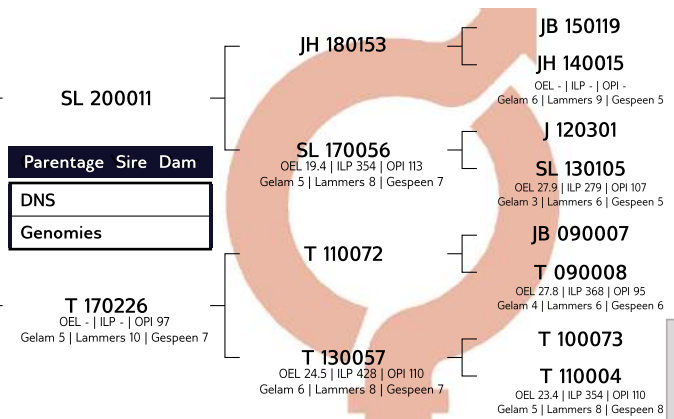

Growth			Reproduction			
Spn. Dir.	Spn. Mat.	Na-Spn.	GLS	TWW	OEL	ILP
89	94	96	104	104	85	95
64%	52%	57%	39%	39%	37%	27%



EBV Analise 2023-09-05

Logix Meriete Indeks	89
Groei Indeks	89
Reproduksie Indeks	94

EKSTEENS HATARI DORMER STUD
Bloemfontein, Free State
0825612917
mariusjnr@diysuper.co.za



VERKOPER OPMERKINGS:

LOT 6 (M)

T 220374



Kuddeboek	SP
Geb. dtm	2022-05-07
Oud.	1.4 jaar
Inteling	10.8%
Geb. Status	2
Nageslag	
Geen	

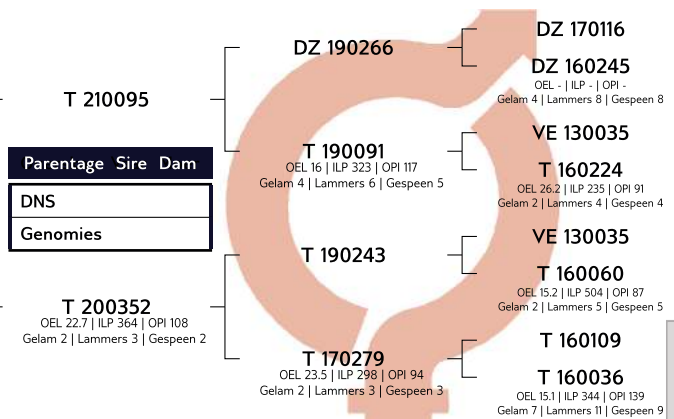

Growth			Reproduction			
Spn. Dir.	Spn. Mat.	Na-Spn.	GLS	TWW	OEL	ILP
110	113	105	95	95	124	89
58%	42%	27%	30%	30%	30%	22%



EBV Analise 2023-09-05

Logix Meriete Indeks	118
Groei Indeks	119
Reproduksie Indeks	115

TWEE BROERS DORMER STOET
Barkly East, Eastern Cape
0723132232
tjaart@barkly.co.za



VERKOPER OPMERKINGS:



HATARI DORMER VEILING

BE-HUMAN16 September 2023



LOT 7 (M)

T 220179



Herd Book	SP
Birth date	2022-05-04
Age	1.4 years
Inbreeding	5.13%
Birth Stat.	1
Progeny	
None	

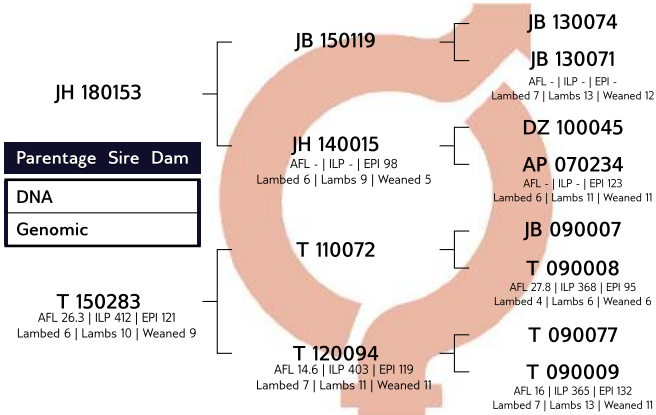

Growth			Reproduction			
Wn. Dir.	Wean Mat.	Post-Wn.	NLW	TWW	AFL	ILP
90	95	90	107	107	87	82
65%	60%	44%	50%	50%	48%	36%



EBV Analysis 2023-09-05

Logix Merit Index	92
Growth Index	91
Reproduction Index	98

TWEE BROERS DORMER STOET
Barkly East, Eastern Cape
0723132232
tjaart@barkly.co.za

SELLER REMARKS:

LOT 8 (M)

T 220265



Herd Book	SP
Birth date	2022-05-04
Age	1.4 years
Inbreeding	6.66%
Birth Stat.	2
Progeny	
None	

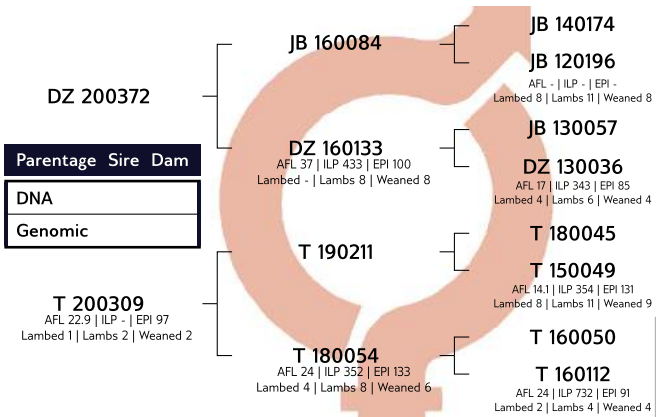

Growth			Reproduction			
Wn. Dir.	Wean Mat.	Post-Wn.	NLW	TWW	AFL	ILP
115	105	109	92	92	108	97
58%	44%	30%	35%	35%	33%	28%



EBV Analysis 2023-09-05

Logix Merit Index	115
Growth Index	121
Reproduction Index	105

TWEE BROERS DORMER STOET
Barkly East, Eastern Cape
0723132232
tjaart@barkly.co.za

SELLER REMARKS:

LOT 9 (M)

T 220446



Herd Book	SP
Birth date	2022-05-07
Age	1.4 years
Inbreeding	6.76%
Birth Stat.	1
Progeny	
None	

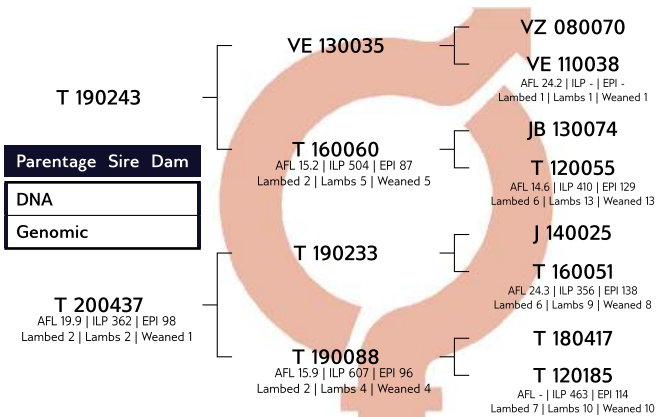

Growth			Reproduction			
Wn. Dir.	Wean Mat.	Post-Wn.	NLW	TWW	AFL	ILP
114	106	106	90	90	118	88
61%	51%	41%	40%	40%	42%	29%



EBV Analysis 2023-09-05

Logix Merit Index	115
Growth Index	120
Reproduction Index	106

TWEE BROERS DORMER STOET
Barkly East, Eastern Cape
0723132232
tjaart@barkly.co.za

SELLER REMARKS:



HATARI DORMER VEILING

BE-HUMAN16 September 2023



LOT 10 (M)

T 220332



Kuddeboek	SP
Geb. dtm	2022-05-07
Oud.	1.4 jaar
Inteling	6.5%
Geb. Status	2
Nageslag	
Geen	

TWEE BROERS DORMER STOET

Barkly East, Eastern Cape
0723132232
tjaart@barkly.co.za

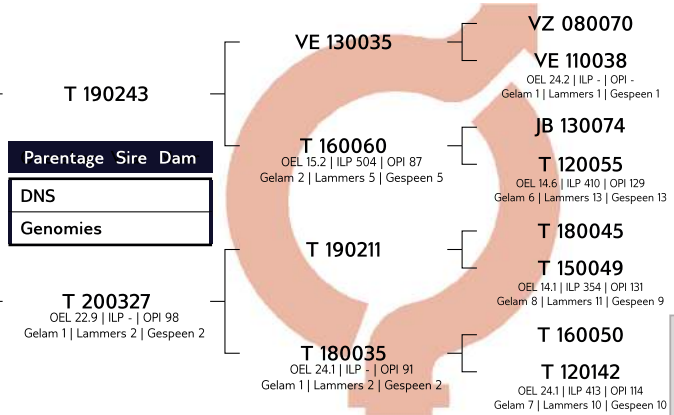

Growth			Reproduction			
Spn. Dir.	Spn. Mat.	Na-Spn.	GLS	TWW	OEL	ILP
114	111	107	100	100	122	94
62%	52%	42%	40%	40%	42%	28%



EBV Analise 2023-09-05

Logix Meriete Indeks	123
Groei Indeks	122
Reproduksie Indeks	119

VERKOPER OPMERKINGS:

LOT 11 (M)

DZ 220055



Kuddeboek	SP
Geb. dtm	2022-02-26
Oud.	1.6 jaar
Inteling	5.83%
Geb. Status	1
Nageslag	
Geen	

2 STEYNS BOERDERY

Venterstad, Eastern Cape
0824782470
steyni903@gmail.com

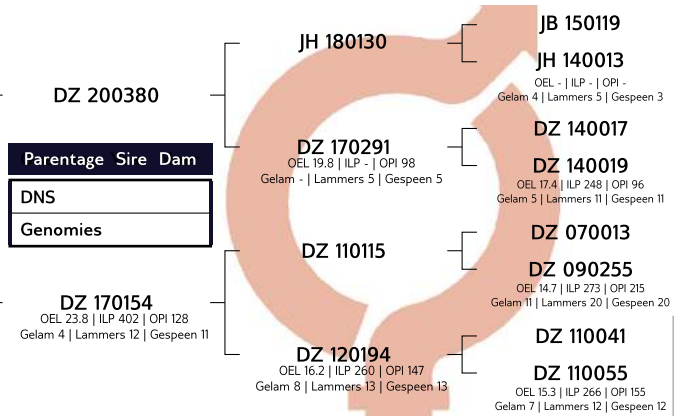

Growth			Reproduction			
Spn. Dir.	Spn. Mat.	Na-Spn.	GLS	TWW	OEL	ILP
111	98	107	90	90	103	98
63%	49%	38%	38%	38%	34%	29%



EBV Analise 2023-09-05

Logix Meriete Indeks	106
Groei Indeks	113
Reproduksie Indeks	96

VERKOPER OPMERKINGS:

LOT 12 (M)

DZ 220013



Kuddeboek	SP
Geb. dtm	2022-02-25
Oud.	1.6 jaar
Inteling	8.94%
Geb. Status	2
Nageslag	
Geen	

2 STEYNS BOERDERY

Venterstad, Eastern Cape
0824782470
steyni903@gmail.com

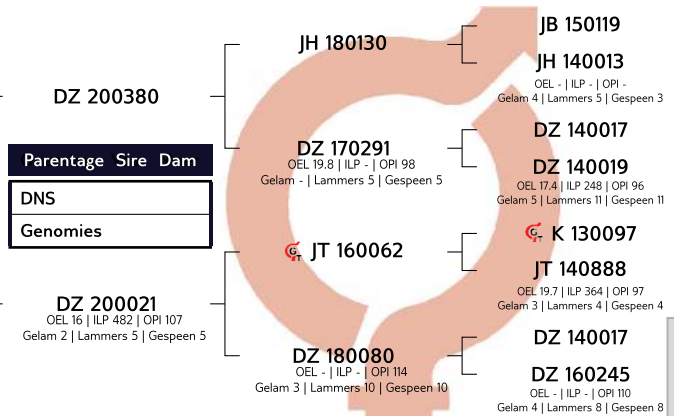

Growth			Reproduction			
Spn. Dir.	Spn. Mat.	Na-Spn.	GLS	TWW	OEL	ILP
122	99	120	105	105	99	90
61%	46%	34%	34%	34%	32%	27%



EBV Analise 2023-09-05

Logix Meriete Indeks	122
Groei Indeks	124
Reproduksie Indeks	110

VERKOPER OPMERKINGS:



HATARI DORMER VEILING

BE-HUMAN16 September 2023



LOT 13 (M)



2 STEYNS BOERDERY
Venterstad, Eastern Cape
0824782470
steyn1903@gmail.com



DZ 220158

Herd Book	SP
Birth date	2022-06-30
Age	1.2 years
Inbreeding	6.51%
Birth Stat.	1
Progeny	
None	

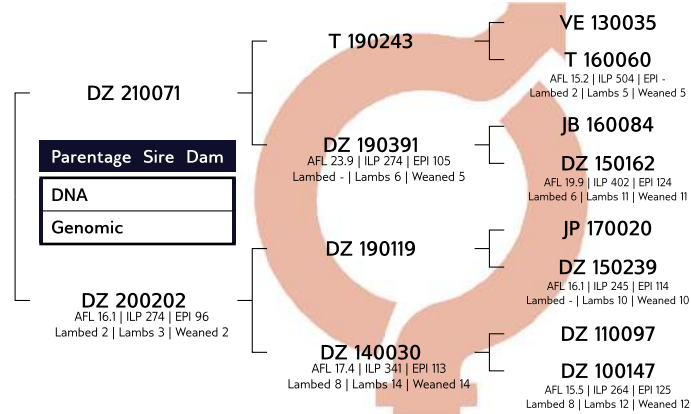

Growth			Reproduction			
Wn. Dir.	Wean Mat.	Post-Wn.	NLW	TWW	AFL	ILP
118	98	115	93	93	109	99
59%	44%	30%	33%	33%	32%	25%



EBV Analysis 2023-09-05

Logix Merit Index	115
Growth Index	120
Reproduction Index	103

SELLER REMARKS:

LOT 14 (M)



2 STEYNS BOERDERY
Venterstad, Eastern Cape
0824782470
steyn1903@gmail.com



DZ 220116

Herd Book	SP
Birth date	2022-06-28
Age	1.2 years
Inbreeding	6.41%
Birth Stat.	2
Progeny	
None	

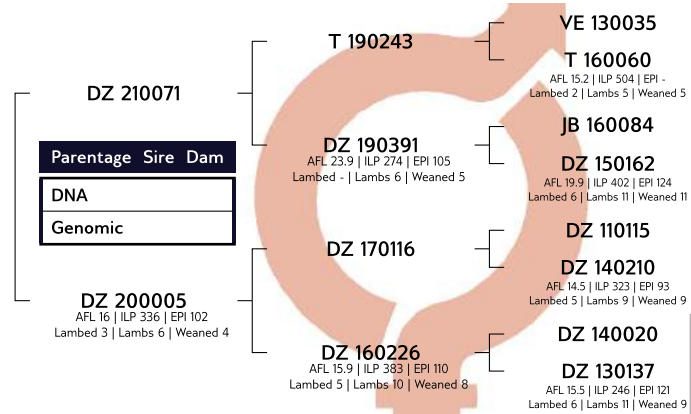

Growth			Reproduction			
Wn. Dir.	Wean Mat.	Post-Wn.	NLW	TWW	AFL	ILP
115	101	111	108	108	113	83
60%	46%	34%	35%	35%	35%	27%



EBV Analysis 2023-09-05

Logix Merit Index	121
Growth Index	119
Reproduction Index	116

SELLER REMARKS:

LOT 15 (M)



2 STEYNS BOERDERY
Venterstad, Eastern Cape
0824782470
steyn1903@gmail.com



DZ 220359

Herd Book	SP
Birth date	2022-09-22
Age	1 years
Inbreeding	8.97%
Birth Stat.	1
Progeny	
None	

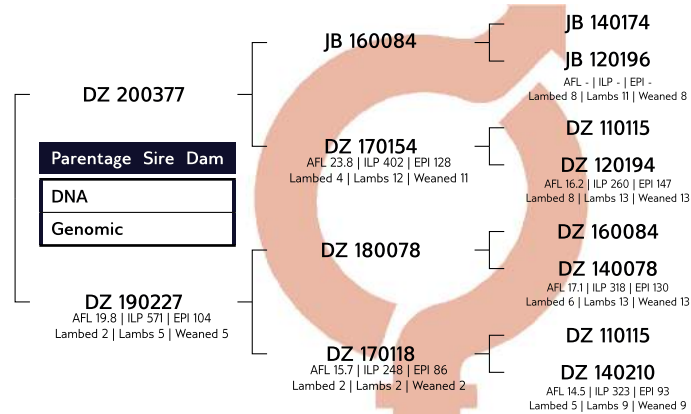

Growth			Reproduction			
Wn. Dir.	Wean Mat.	Post-Wn.	NLW	TWW	AFL	ILP
111	101	107	96	96	70	104
58%	46%	35%	37%	37%	35%	30%



EBV Analysis 2023-09-05

Logix Merit Index	105
Growth Index	115
Reproduction Index	94

SELLER REMARKS:



HATARI DORMER VEILING

BE-HUMAN16 September 2023



LOT 16 (M)

HE 220062



Kuddeboek	SP
Geb. dtm	2022-07-22
Oud.	1.1 jaar
Inteling	6.99%
Geb. Status	2
Nageslag	
Geen	

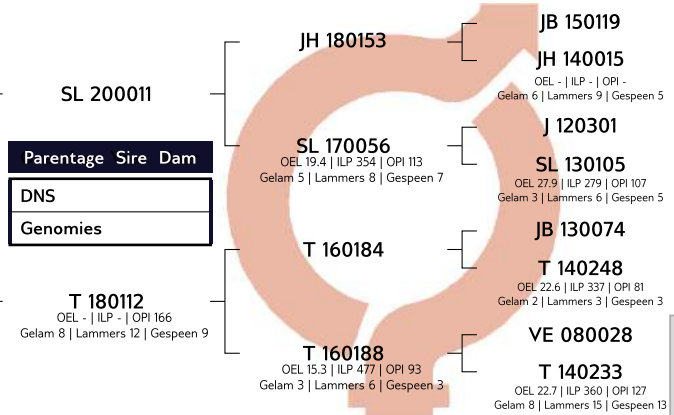

Growth			Reproduction			
Spn. Dir.	Spn. Mat.	Na-Spn.	GLS	TWW	OEL	ILP
109	101	106	106	106	90	113
64%	52%	60%	38%	38%	36%	26%



EBV Analise 2023-09-05

Logix Meriete Indeks	113
Groei Indeks	112
Reproduksie Indeks	109

VERKOPER OPMERKINGS:

LOT 17 (M)

HE 220073



Kuddeboek	SP
Geb. dtm	2022-07-21
Oud.	1.2 jaar
Inteling	4.49%
Geb. Status	2
Nageslag	
Geen	

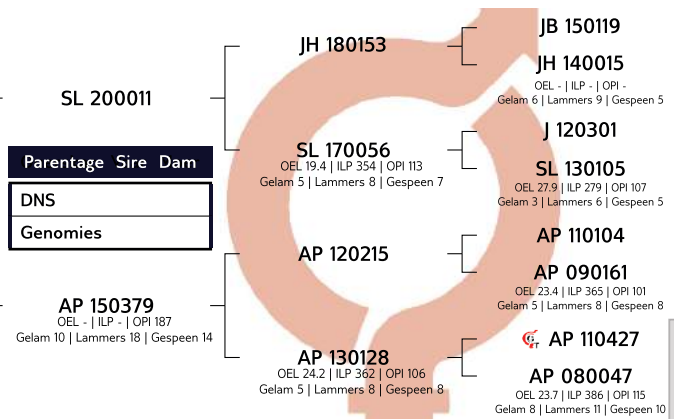

Growth			Reproduction			
Spn. Dir.	Spn. Mat.	Na-Spn.	GLS	TWW	OEL	ILP
97	96	101	100	100	101	103
64%	53%	61%	40%	40%	36%	26%



EBV Analise 2023-09-05

Logix Meriete Indeks	100
Groei Indeks	99
Reproduksie Indeks	101

VERKOPER OPMERKINGS:

LOT 18 (M)

HE 220074



Kuddeboek	SP
Geb. dtm	2022-07-21
Oud.	1.2 jaar
Inteling	5.75%
Geb. Status	2
Nageslag	
Geen	

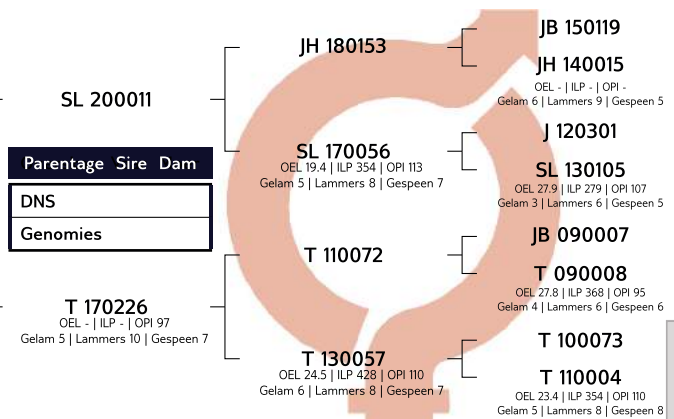

Growth			Reproduction			
Spn. Dir.	Spn. Mat.	Na-Spn.	GLS	TWW	OEL	ILP
91	94	103	104	104	85	95
64%	52%	57%	39%	39%	37%	27%



EBV Analise 2023-09-05

Logix Meriete Indeks	91
Groei Indeks	91
Reproduksie Indeks	95

VERKOPER OPMERKINGS:



HATARI DORMER VEILING

BE-HUMAN16 September 2023



LOT 19 (M)

HE 220076



Herd Book	SP
Birth date	2022-07-21
Age	1.2 years
Inbreeding	5.75%
Birth Stat.	2
Progeny	
None	

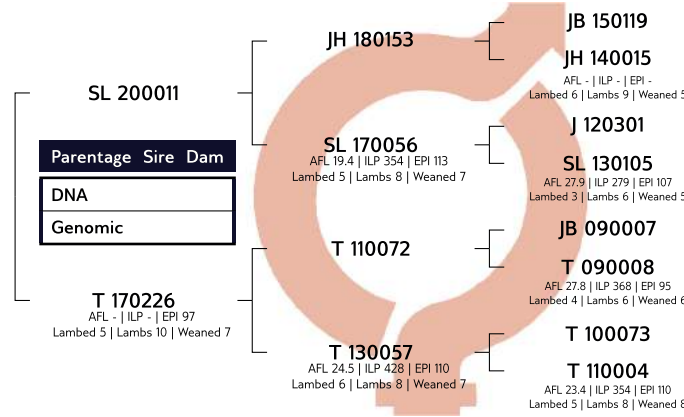

Growth			Reproduction			
Wn. Dir.	Wean Mat.	Post-Wn.	NLW	TWW	AFL	ILP
93	92	100	104	104	85	95
64%	52%	57%	39%	39%	37%	27%



EBV Analysis 2023-09-05

Logix Merit Index	92
Growth Index	92
Reproduction Index	94

EKSTEENS HATARI DORMER STUD

Bloemfontein, Free State
0825612917
mariusjnr@diysuper.co.za



SELLER REMARKS:

LOT 20 (M)

HE 220077



Herd Book	SP
Birth date	2022-07-19
Age	1.2 years
Inbreeding	4.76%
Birth Stat.	1
Progeny	
None	

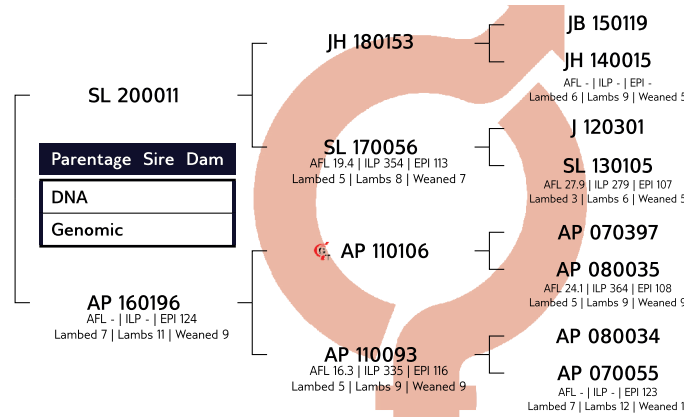

Growth			Reproduction			
Wn. Dir.	Wean Mat.	Post-Wn.	NLW	TWW	AFL	ILP
104	87	99	85	85	80	120
64%	53%	61%	39%	39%	37%	26%



EBV Analysis 2023-09-05

Logix Merit Index	91
Growth Index	101
Reproduction Index	79

EKSTEENS HATARI DORMER STUD

Bloemfontein, Free State
0825612917
mariusjnr@diysuper.co.za



SELLER REMARKS:

LOT 21 (M)

T 220316



Herd Book	SP
Birth date	2022-05-07
Age	1.4 years
Inbreeding	5.92%
Birth Stat.	3
Progeny	
None	

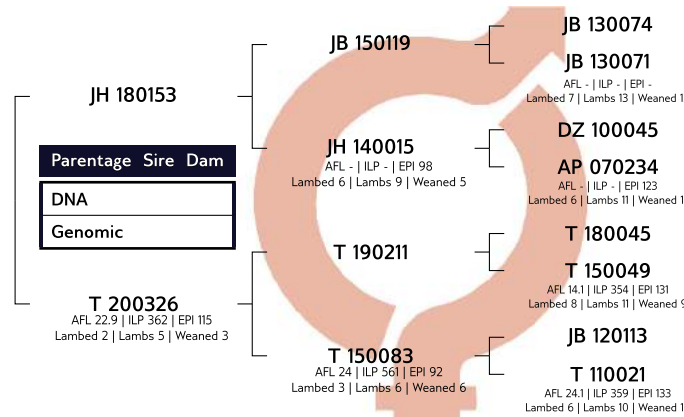

Growth			Reproduction			
Wn. Dir.	Wean Mat.	Post-Wn.	NLW	TWW	AFL	ILP
104	97	99	114	114	90	113
63%	56%	44%	46%	46%	46%	34%



EBV Analysis 2023-09-05

Logix Merit Index	112
Growth Index	106
Reproduction Index	112

TWEE BROERS DORMER STOET

Barkly East, Eastern Cape
0723132232
tjart@barkly.co.za



SELLER REMARKS:



HATARI DORMER VEILING

BE-HUMAN16 September 2023



LOT 22 (M)

T 220008



Kuddeboek	SP
Geb. dtm	2022-04-29
Oud.	1.4 jaar
Inteling	9.19%
Geb. Status	2
Nageslag	
Geen	

TWEE BROERS DORMER STOET

Barkly East, Eastern Cape
0723132232
tjaart@barkly.co.za

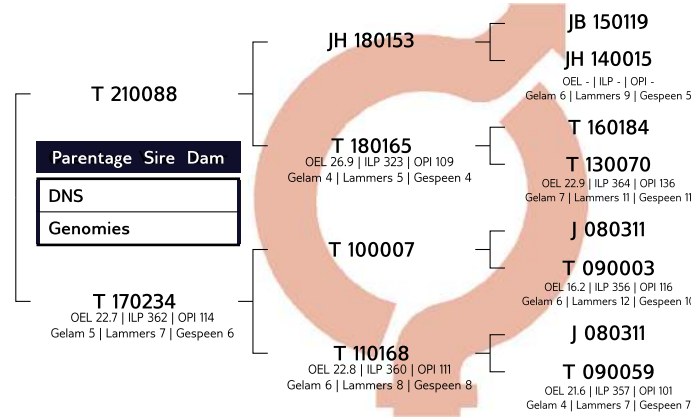

Growth			Reproduction			
Spn. Dir.	Spn. Mat.	Na-Spn.	GLS	TWW	OEL	ILP
93	97	93	91	91	108	94
59%	47%	29%	38%	38%	34%	28%



EBV Analyse 2023-09-05

Logix Meriete Indeks	92
Groei Indeks	95
Reproduksie Indeks	94

VERKOPER OPMERKINGS:

LOT 23 (M)

T 220456



Kuddeboek	SP
Geb. dtm	2022-05-07
Oud.	1.4 jaar
Inteling	5.85%
Geb. Status	3
Nageslag	
Geen	

TWEE BROERS DORMER STOET

Barkly East, Eastern Cape
0723132232
tjaart@barkly.co.za

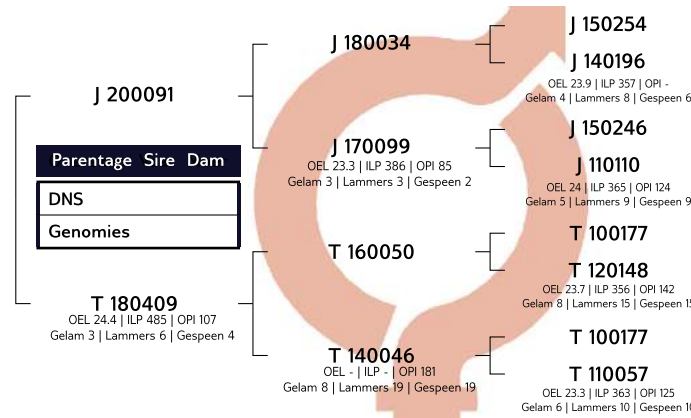

Growth			Reproduction			
Spn. Dir.	Spn. Mat.	Na-Spn.	GLS	TWW	OEL	ILP
95	96	90	108	108	101	98
61%	45%	26%	34%	34%	31%	25%



EBV Analyse 2023-09-05

Logix Meriete Indeks	102
Groei Indeks	96
Reproduksie Indeks	107

VERKOPER OPMERKINGS:

LOT 24 (M)

T 220089



Kuddeboek	SP
Geb. dtm	2022-05-01
Oud.	1.4 jaar
Inteling	11.57%
Geb. Status	2
Nageslag	
Geen	

TWEE BROERS DORMER STOET

Barkly East, Eastern Cape
0723132232
tjaart@barkly.co.za

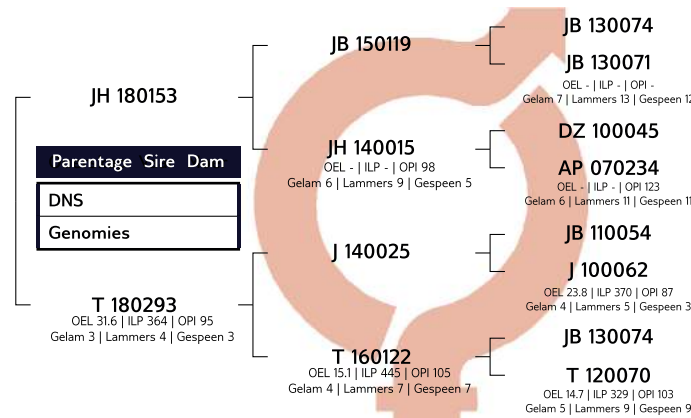

Growth			Reproduction			
Spn. Dir.	Spn. Mat.	Na-Spn.	GLS	TWW	OEL	ILP
93	88	92	94	94	81	106
63%	58%	46%	49%	49%	49%	37%



EBV Analyse 2023-09-05

Logix Meriete Indeks	86
Groei Indeks	91
Reproduksie Indeks	84

VERKOPER OPMERKINGS:



HATARI DORMER VEILING

BE-HUMAN16 September 2023



LOT 25 (M)

T 220159



Herd Book	SP
Birth date	2022-05-01
Age	1.4 years
Inbreeding	18.39%
Birth Stat.	3
Progeny	None

TWEE BROERS DORMER STOET

Barkly East, Eastern Cape
0723132232
tjaart@barkly.co.za

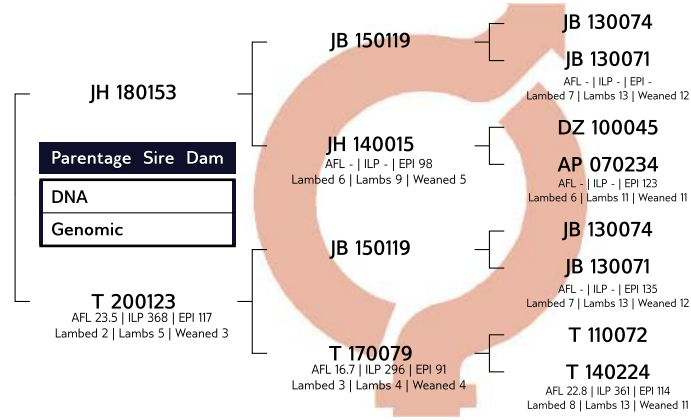

Growth			Reproduction			
Wn. Dir.	Wean Mat.	Post-Wn.	NLW	TWW	AFL	ILP
110	91	106	106	106	81	93
63%	57%	46%	48%	48%	48%	36%



EBV Analysis 2023-09-05

Logix Merit Index	106
Growth Index	109
Reproduction Index	98

SELLER REMARKS:

LOT 26 (M)

DZ 220189



Herd Book	SP
Birth date	2022-07-01
Age	1.2 years
Inbreeding	10.98%
Birth Stat.	1
Progeny	None

2 STEYNS BOERDERY

Venterstad, Eastern Cape
0824782470
steyn1903@gmail.com

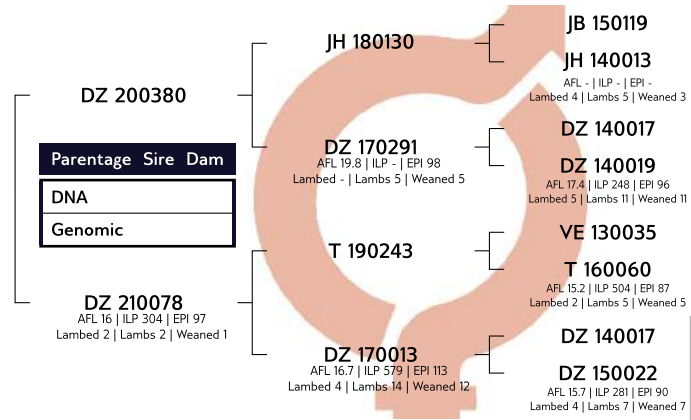

Growth			Reproduction			
Wn. Dir.	Wean Mat.	Post-Wn.	NLW	TWW	AFL	ILP
119	103	113	96	96	113	86
60%	43%	34%	32%	32%	31%	25%



EBV Analysis 2023-09-05

Logix Merit Index	119
Growth Index	123
Reproduction Index	108

SELLER REMARKS:

LOT 27 (M)

DZ 220136



Herd Book	SP
Birth date	2022-06-29
Age	1.2 years
Inbreeding	12.54%
Birth Stat.	1
Progeny	None

2 STEYNS BOERDERY

Venterstad, Eastern Cape
0824782470
steyn1903@gmail.com

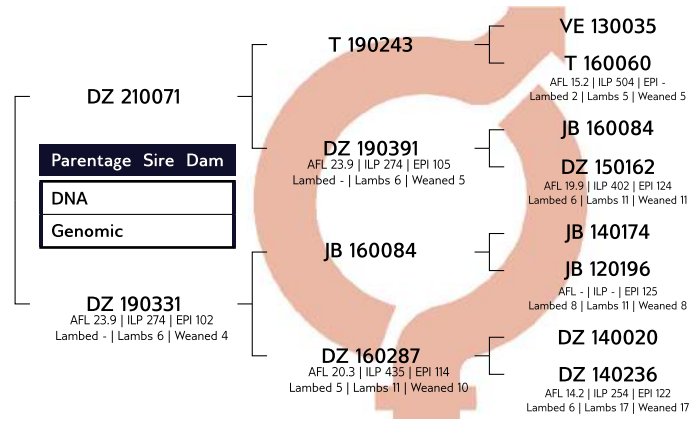

Growth			Reproduction			
Wn. Dir.	Wean Mat.	Post-Wn.	NLW	TWW	AFL	ILP
111	105	109	92	92	104	83
60%	46%	36%	37%	37%	36%	30%



EBV Analysis 2023-09-05

Logix Merit Index	109
Growth Index	116
Reproduction Index	101

SELLER REMARKS:

LOT 28 (M)

HE 220097



Kuddeboek	SP
Geb. dtm	2022-07-23
Oud.	1.1 jaar
Inteling	9.67%
Geb. Status	2
Nageslag	
Geen	

SL 200011

Parentage Sire Dam

DNS

Genomies

SL 180140

OEL - | ILP - | OPI 163
Gelam 10 | Lammers 13 | Gespeen 11

JH 180153

SL 170056
OEL 19.4 | ILP 354 | OPI 113
Gelam 5 | Lammers 8 | Gespeen 7

SL 170032

SL 160036
OEL 28 | ILP 332 | OPI 90
Gelam 2 | Lammers 3 | Gespeen 3

JB 150119

JH 140015

OEL - | ILP - | OPI -
Gelam 6 | Lammers 9 | Gespeen 5

J 120301

SL 130105

OEL 27.9 | ILP 279 | OPI 107
Gelam 3 | Lammers 6 | Gespeen 5

J 120301

SL 140009

OEL 17.5 | ILP 365 | OPI 104
Gelam 7 | Lammers 9 | Gespeen 8

SL 140073

SL 120070

OEL 16.8 | ILP 355 | OPI 180
Gelam 8 | Lammers 15 | Gespeen 15

Growth			Reproduction			
Spn. Dir.	Spn. Mat.	Na-Spn.	GLS	TWW	OEL	ILP
95	100	94	106	106	80	114
63%	51%	59%	35%	35%	32%	23%



EBV Analise 2023-09-05

Logix Meriete Indeks **99**

Groei Indeks **98**

Reproduksie Indeks **102**

VERKOPER OPMERKINGS:

LOT 29 (M)

HE 220121



Kuddeboek	SP
Geb. dtm	2022-08-11
Oud.	1.1 jaar
Inteling	4.28%
Geb. Status	3
Nageslag	
Geen	

SL 200011

Parentage Sire Dam

DNS

Genomies

NB 160907

OEL 19.7 | ILP 363 | OPI 130
Gelam 6 | Lammers 16 | Gespeen 10

JH 180153

SL 170056
OEL 19.4 | ILP 354 | OPI 113
Gelam 5 | Lammers 8 | Gespeen 7

NB 140318

NB 120133
OEL 14.3 | ILP 356 | OPI 128
Gelam 6 | Lammers 11 | Gespeen 11

JB 150119

JH 140015

OEL - | ILP - | OPI -
Gelam 6 | Lammers 9 | Gespeen 5

J 120301

SL 130105

OEL 27.9 | ILP 279 | OPI 107
Gelam 3 | Lammers 6 | Gespeen 5

K 100045

NB 120135

OEL 13.9 | ILP 297 | OPI 137
Gelam 8 | Lammers 14 | Gespeen 11

K 100045

NB 100034

OEL 26.5 | ILP 357 | OPI 97
Gelam 4 | Lammers 7 | Gespeen 6

Growth			Reproduction			
Spn. Dir.	Spn. Mat.	Na-Spn.	GLS	TWW	OEL	ILP
111	105	118	106	106	79	104
63%	53%	58%	39%	39%	37%	27%



EBV Analise 2023-09-05

Logix Meriete Indeks **113**

Groei Indeks **117**

Reproduksie Indeks **107**

VERKOPER OPMERKINGS:

LOT 30 (M)

HE 220139



Kuddeboek	SP
Geb. dtm	2022-08-08
Oud.	1.1 jaar
Inteling	4.88%
Geb. Status	2
Nageslag	
Geen	

SL 200011

Parentage Sire Dam

DNS

Genomies

NB 200476

OEL 13.6 | ILP 345 | OPI 137
Gelam 3 | Lammers 5 | Gespeen 4

JH 180153

SL 170056
OEL 19.4 | ILP 354 | OPI 113
Gelam 5 | Lammers 8 | Gespeen 7

NL 180031

NB 180089
OEL - | ILP - | OPI 142
Gelam 6 | Lammers 11 | Gespeen 7

JB 150119

JH 140015

OEL - | ILP - | OPI -
Gelam 6 | Lammers 9 | Gespeen 5

J 120301

SL 130105

OEL 27.9 | ILP 279 | OPI 107
Gelam 3 | Lammers 6 | Gespeen 5

ASJ 120435

NL 150401

OEL 23.4 | ILP 352 | OPI 86
Gelam 2 | Lammers 3 | Gespeen 3

JB 160084

NB 130173

OEL 25.6 | ILP 301 | OPI 89
Gelam 4 | Lammers 5 | Gespeen 4

Growth			Reproduction			
Spn. Dir.	Spn. Mat.	Na-Spn.	GLS	TWW	OEL	ILP
103	94	98	97	97	76	114
62%	50%	57%	37%	37%	35%	26%



EBV Analise 2023-09-05

Logix Meriete Indeks **98**

Groei Indeks **103**

Reproduksie Indeks **92**

VERKOPER OPMERKINGS:



HATARI DORMER VEILING

BE-HUMAN16 September 2023



LOT 31 (M)

HE 220114



Herd Book	SP
Birth date	2022-08-12
Age	1.1 years
Inbreeding	5.69%
Birth Stat.	2
Progeny	None

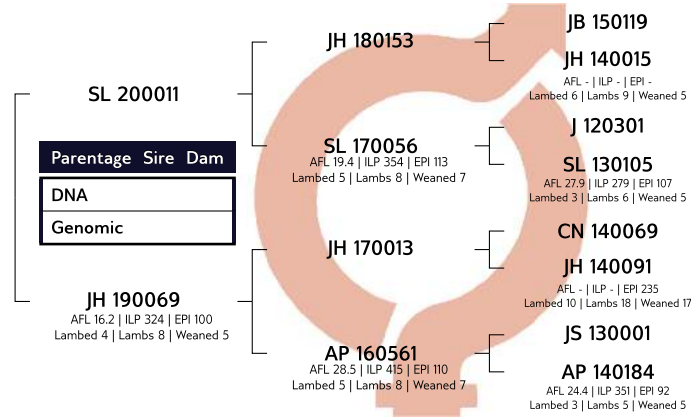

Growth			Reproduction			
Wn. Dir.	Wean Mat.	Post-Wn.	NLW	TWW	AFL	ILP
104	105	106	114	114	78	111
62%	50%	51%	37%	37%	34%	24%



EBV Analysis 2023-09-05

Logix Merit Index	113
Growth Index	110
Reproduction Index	114

SELLER REMARKS:

EKSTEENS HATARI DORMER STUD

Bloemfontein, Free State
0825612917
mariusjnr@diysuper.co.za



LOT 32 (M)

HE 220134



Herd Book	SP
Birth date	2022-08-14
Age	1.1 years
Inbreeding	6.95%
Birth Stat.	1
Progeny	None

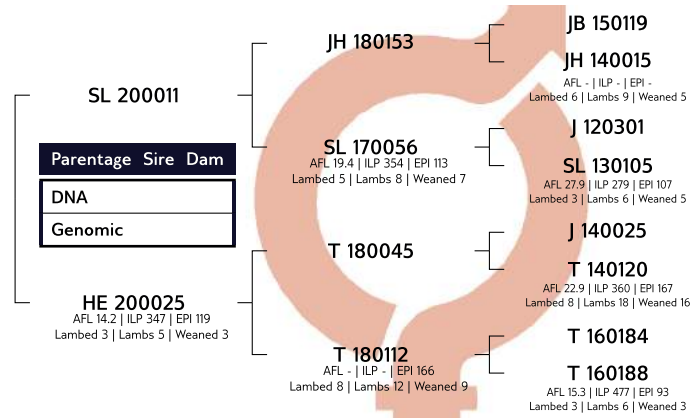

Growth			Reproduction			
Wn. Dir.	Wean Mat.	Post-Wn.	NLW	TWW	AFL	ILP
108	99	99	103	103	83	112
62%	50%	56%	37%	37%	36%	26%



EBV Analysis 2023-09-05

Logix Merit Index	109
Growth Index	110
Reproduction Index	103

SELLER REMARKS:

EKSTEENS HATARI DORMER STUD

Bloemfontein, Free State
0825612917
mariusjnr@diysuper.co.za



LOT 33 (M)

T 220589



Herd Book	SP
Birth date	2022-10-21
Age	11 months
Inbreeding	9.74%
Birth Stat.	1
Progeny	None

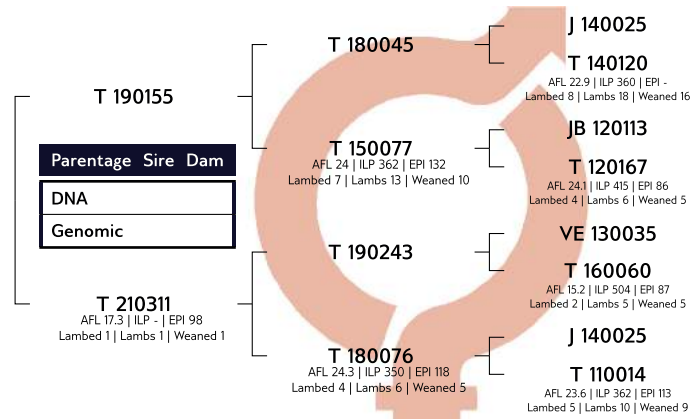

Growth			Reproduction			
Wn. Dir.	Wean Mat.	Post-Wn.	NLW	TWW	AFL	ILP
102	97	95	103	103	95	108
59%	45%	31%	34%	34%	33%	25%



EBV Analysis 2023-09-05

Logix Merit Index	105
Growth Index	103
Reproduction Index	103

SELLER REMARKS:

TWEE BROERS DORMER STOET

Barkly East, Eastern Cape
0723132232
tjart@barkly.co.za



PAYBACK : DZ19-389

Vaar van Tyson & Dallas

Payback is n ongelooflike goed gebalanseerde Ram wat sy teel vermoë deur en deur bewys het in die Dormer bedryf.

Paypack is die Vaar van Tyson, Dallas en Blaser wat van die belowendste ramme in die Dormer bedryf is.

Tyson was in sy klas op die Royal Show 2023 die wenner met 'n sterk form en dominansie soos min. As dit gaan oor RAM wees, is hy die modelkind van wat 'n Dormer ram moet wees.

Dallas het die hoogste prys op die 2023 Nasionale Dormer Veiling behaal. Dit is ook een van die korrekste Dormer ramme wat daar is op fenotipe sowal as uitstaande syfers!! Dallas skree balans balans balans...



TYSON

DZ21-225 (Royal Show 18-24 maande wenner)



DALLAS

DZ21-297 (Nasionaal 2023 Duurste Ram)



HATARI DORMER VEILING

BE-HUMAN16 September 2023



LOT 34 (F)

HE 220024



Kuddeboek	SP	
Geb. dtm	2022-07-21	
Oud.	1.2 jaar	
Inteling	5.4%	
Geb. Status	3	
OEL	ILP	OPI
-	-	-

SL 200011

Parentage Sire Dam

DNS

Genomies

T 170151
OEL - | ILP - | OPI 116
Gelum 7 | Lammers 11 | Gespeen 9

JH 180153

SL 170056
OEL 19.4 | ILP 354 | OPI 113
Gelum 5 | Lammers 8 | Gespeen 7

T 140300

T 140033
OEL 24.5 | ILP 351 | OPI 98
Gelum 5 | Lammers 7 | Gespeen 7

JB 150119

JH 140015
OEL - | ILP - | OPI -
Gelum 6 | Lammers 9 | Gespeen 5

J 120301

SL 130105
OEL 27.9 | ILP 279 | OPI 107
Gelum 3 | Lammers 6 | Gespeen 5

T 110072

T 100061
OEL 24.6 | ILP 364 | OPI 89
Gelum 3 | Lammers 4 | Gespeen 4

T 110072

T 090082
OEL 21.4 | ILP 352 | OPI 120
Gelum 6 | Lammers 10 | Gespeen 10

Growth			Reproduction			
Spn. Dir.	Spn. Mat.	Na-Spn.	GLS	TWW	OEL	ILP
92	96	92	107	107	87	85
63%	52%	57%	38%	38%	36%	26%



EBV Analise 2023-09-05

Logix Meriete Indeks **94**

Groei Indeks **93**

Reproduksie Indeks **99**

VERKOPER OPMERKINGS:Oop ooi. Kom saam met n Payback DZ190389 strooitjie.

LOT 35 (F)

HE 220072



Kuddeboek	SP	
Geb. dtm	2022-07-22	
Oud.	1.1 jaar	
Inteling	5.4%	
Geb. Status	1	
OEL	ILP	OPI
-	-	-

SL 200011

Parentage Sire Dam

DNS

Genomies

T 170151
OEL - | ILP - | OPI 116
Gelum 7 | Lammers 11 | Gespeen 9

JH 180153

SL 170056
OEL 19.4 | ILP 354 | OPI 113
Gelum 5 | Lammers 8 | Gespeen 7

T 140300

T 140033
OEL 24.5 | ILP 351 | OPI 98
Gelum 5 | Lammers 7 | Gespeen 7

JB 150119

JH 140015
OEL - | ILP - | OPI -
Gelum 6 | Lammers 9 | Gespeen 5

J 120301

SL 130105
OEL 27.9 | ILP 279 | OPI 107
Gelum 3 | Lammers 6 | Gespeen 5

T 110072

T 100061
OEL 24.6 | ILP 364 | OPI 89
Gelum 3 | Lammers 4 | Gespeen 4

T 110072

T 090082
OEL 21.4 | ILP 352 | OPI 120
Gelum 6 | Lammers 10 | Gespeen 10

Growth			Reproduction			
Spn. Dir.	Spn. Mat.	Na-Spn.	GLS	TWW	OEL	ILP
95	95	93	107	107	87	85
63%	52%	57%	38%	38%	36%	26%



EBV Analise 2023-09-05

Logix Meriete Indeks **96**

Groei Indeks **96**

Reproduksie Indeks **99**

VERKOPER OPMERKINGS:Oop ooi. Kom saam met n Payback DZ190389 strooitjie.

LOT 36 (F)

HE 220042



Kuddeboek	SP	
Geb. dtm	2022-07-19	
Oud.	1.2 jaar	
Inteling	5.34%	
Geb. Status	2	
OEL	ILP	OPI
-	-	-

SL 200011

Parentage Sire Dam

DNS

Genomies

T 170117
OEL - | ILP - | OPI 139
Gelum 7 | Lammers 12 | Gespeen 9

JH 180153

SL 170056
OEL 19.4 | ILP 354 | OPI 113
Gelum 5 | Lammers 8 | Gespeen 7

T 140300

T 140231
OEL 22.7 | ILP 360 | OPI 115
Gelum 8 | Lammers 13 | Gespeen 12

JB 150119

JH 140015
OEL - | ILP - | OPI -
Gelum 6 | Lammers 9 | Gespeen 5

J 120301

SL 130105
OEL 27.9 | ILP 279 | OPI 107
Gelum 3 | Lammers 6 | Gespeen 5

T 110072

T 100061
OEL 24.6 | ILP 364 | OPI 89
Gelum 3 | Lammers 4 | Gespeen 4

T 100177

T 090066
OEL 21.6 | ILP 356 | OPI 100
Gelum 4 | Lammers 7 | Gespeen 7

Growth			Reproduction			
Spn. Dir.	Spn. Mat.	Na-Spn.	GLS	TWW	OEL	ILP
89	89	82	99	99	75	102
64%	53%	58%	39%	39%	37%	27%



EBV Analise 2023-09-05

Logix Meriete Indeks **84**

Groei Indeks **87**

Reproduksie Indeks **85**

VERKOPER OPMERKINGS:

LOT 37 (F)



EKSTEENS HATARI DORMER STUD

Bloemfontein, Free State
0825612917
mariusjnr@diysuper.co.za



HE 220103

Herd Book	SP	
Birth date	2022-08-10	
Age	1.1 years	
Inbreeding	5.56%	
Birth Stat.	2	
AFL	ILP	EPI
-	-	-

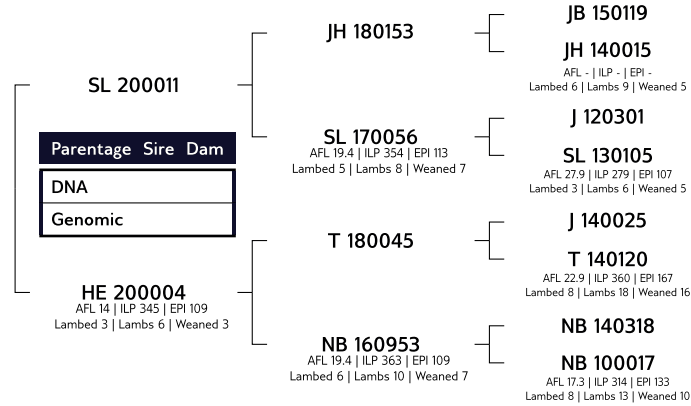

Growth			Reproduction			
Wn. Dir.	Wean Mat.	Post-Wn.	NLW	TWW	AFL	ILP
105	98	102	94	94	77	113
61%	50%	56%	38%	38%	36%	26%



EBV Analysis 2023-09-05

Logix Merit Index	100
Growth Index	108
Reproduction Index	92

SELLER REMARKS: Oop ooi. Kom saam met n Payback DZ190389 strooitjie.

LOT 38 (F)



EKSTEENS HATARI DORMER STUD

Bloemfontein, Free State
0825612917
mariusjnr@diysuper.co.za



HE 220049

Herd Book	SP	
Birth date	2022-07-22	
Age	1.1 years	
Inbreeding	6.99%	
Birth Stat.	2	
AFL	ILP	EPI
-	-	-

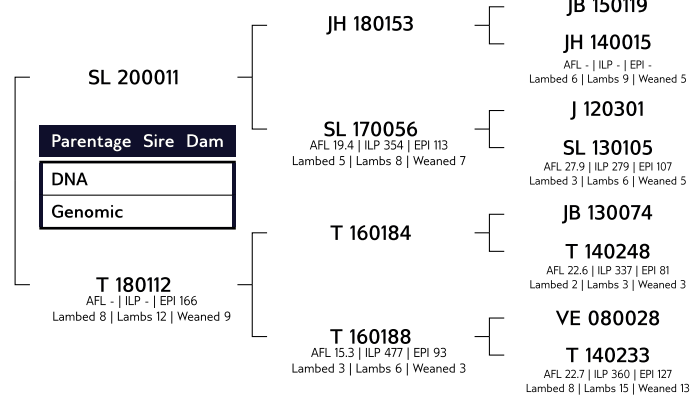

Growth			Reproduction			
Wn. Dir.	Wean Mat.	Post-Wn.	NLW	TWW	AFL	ILP
107	101	104	106	106	90	113
64%	52%	60%	38%	38%	36%	26%



EBV Analysis 2023-09-05

Logix Merit Index	112
Growth Index	110
Reproduction Index	109

SELLER REMARKS: Oop ooi. Kom saam met n Payback DZ190389 strooitjie.

LOT 39 (F)



TWEE BROERS DORMER STOET

Barkly East, Eastern Cape
0723132232
tjart@barkly.co.za



T 200020

Herd Book	SP	
Birth date	2020-05-12	
Age	3.4 years	
Inbreeding	4.89%	
Birth Stat.	1	
AFL	ILP	EPI
23.6m	362d	95
Lambd	2	
Lams	2	
Weaned	1	

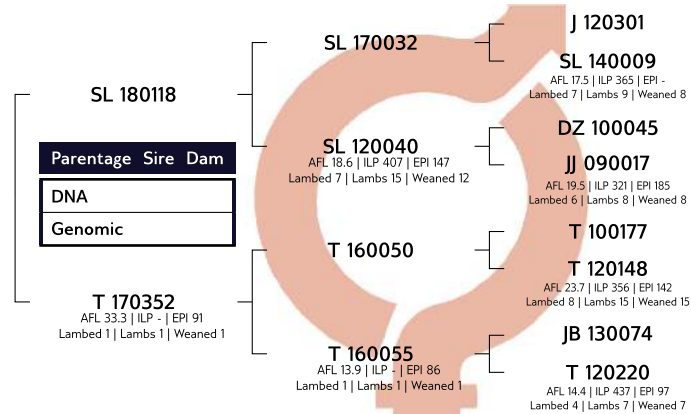

Growth			Reproduction			
Wn. Dir.	Wean Mat.	Post-Wn.	NLW	TWW	AFL	ILP
81	101	81	75	75	90	103
61%	54%	27%	45%	45%	43%	33%



EBV Analysis 2023-09-05

Logix Merit Index	73
Growth Index	85
Reproduction Index	76

SELLER REMARKS: Weer dragtig met eenling. Met ram lam T 230059. Lam kom gratis saam ooi. Vaar is Oorlog SL 180011.

LOT 40 (F)



TWEE BROERS DORMER STOET

Barkly East, Eastern Cape
0723132232
tjaart@barkly.co.za



T 200045

Kuddeboek	SP
Geb. dtm	2020-05-14
Oud.	3.3 jaar
Inteling	4.61%
Geb. Status	2

OEL	ILP	OPI
23.7m	367d	97

Gelam	2
Lammers	2
Gespeen	1

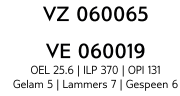
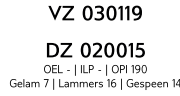
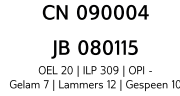
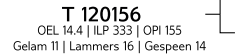
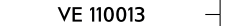
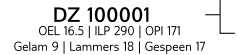
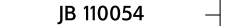
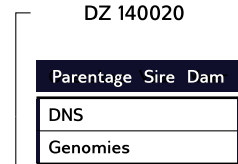

Growth			Reproduction			
Spn. Dir.	Spn. Mat.	Na-Spn.	GLS	TWW	OEL	ILP
97	108	94	76	76	78	86
65%	64%	50%	57%	57%	53%	46%



EBV Analise 2023-09-05

Logix Meriete Indeks **85**

Groei Indeks **104**

Reproduksie Indeks **79**

VERKOPER OPMERKINGS: Weer dragtig met tweeling. Met ooi lam T 230462. Lam kom gratis saam ooi. Vaar is Daan JH 180153.

LOT 41 (F)



TWEE BROERS DORMER STOET

Barkly East, Eastern Cape
0723132232
tjaart@barkly.co.za



T 200008

Kuddeboek	SP
Geb. dtm	2020-05-11
Oud.	3.4 jaar
Inteling	4.77%
Geb. Status	2

OEL	ILP	OPI
23.7m	362d	111

Gelam	2
Lammers	4
Gespeen	2

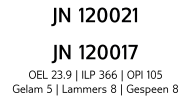
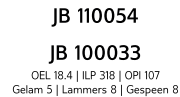
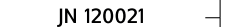
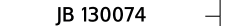
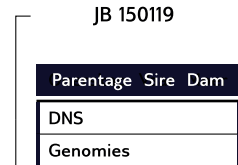

Growth			Reproduction			
Spn. Dir.	Spn. Mat.	Na-Spn.	GLS	TWW	OEL	ILP
100	101	100	64	64	91	101
65%	63%	39%	51%	51%	48%	38%



EBV Analise 2023-09-05

Logix Meriete Indeks **83**

Groei Indeks **104**

Reproduksie Indeks **71**

VERKOPER OPMERKINGS: Weer dragtig met tweeling. Met tweeling ooi lammers T 230057 en T230058. Lam kom gratis saam ooi. Vaar is Daan JH 180153.

LOT 42 (F)



TWEE BROERS DORMER STOET

Barkly East, Eastern Cape
0723132232
tjaart@barkly.co.za

T 200404

Kuddeboek	SP
Geb. dtm	2020-09-05
Oud.	3 jaar
Inteling	7.67%
Geb. Status	2

OEL	ILP	OPI
19.9m	361d	100

Gelam	2
Lammers	3
Gespeen	1

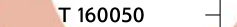
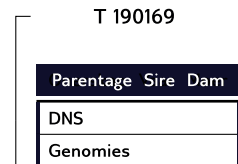

Growth			Reproduction			
Spn. Dir.	Spn. Mat.	Na-Spn.	GLS	TWW	OEL	ILP
91	102	87	97	97	109	92
57%	53%	25%	44%	44%	40%	33%



EBV Analise 2023-09-05

Logix Meriete Indeks **96**

Groei Indeks **95**

Reproduksie Indeks **102**

VERKOPER OPMERKINGS: Dragtig met eenling van Topgun T21 0095.



HATARI DORMER VEILING

BE-HUMAN16 September 2023



LOT 43 (F)



TWEE BROERS DORMER STOET

Barkly East, Eastern Cape
0723132232
tjaart@barkly.co.za



T 210127

Herd Book	SP	
Birth date	2021-05-07	
Age	2.4 years	
Inbreeding	4.89%	
Birth Stat.	2	
AFL	ILP	EPI
16.7m	-	96
Lambd	1	
Lambs	1	
Weaned	1	

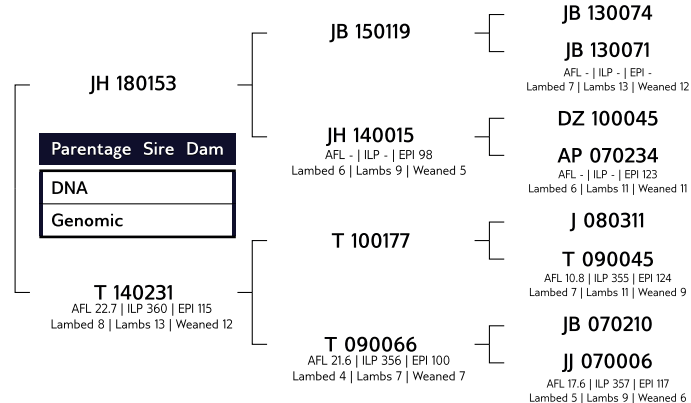

Growth			Reproduction			
Wn. Dir.	Wean Mat.	Post-Wn.	NLW	TWW	AFL	ILP
89	79	82	100	100	90	109
66%	64%	46%	53%	53%	52%	38%



EBV Analysis 2023-09-05

Logix Merit Index	84
Growth Index	82
Reproduction Index	86

SELLER REMARKS: Dragtig met eenling van Topgun T21 0095.

LOT 44 (F)



2 STEYNS BOERDERY

Venterstad, Eastern Cape
0824782470
steyn1903@gmail.com



DZ 220250

Herd Book	SP	
Birth date	2022-07-02	
Age	1.2 years	
Inbreeding	8.29%	
Birth Stat.	3	
AFL	ILP	EPI
-	-	-

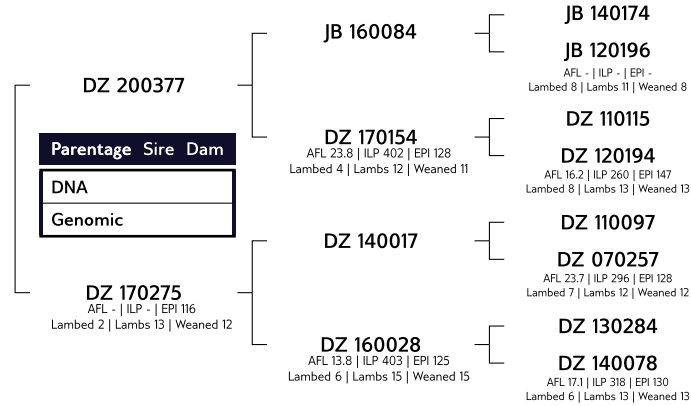

Growth			Reproduction			
Wn. Dir.	Wean Mat.	Post-Wn.	NLW	TWW	AFL	ILP
91	96	91	111	111	104	102
59%	50%	39%	42%	42%	39%	34%



EBV Analysis 2023-09-05

Logix Merit Index	101
Growth Index	92
Reproduction Index	110

SELLER REMARKS: Dragtig van Tyson DZ 21 0225.

LOT 46 (F)



2 STEYNS BOERDERY

Venterstad, Eastern Cape
0824782470
steyn1903@gmail.com



DZ 210188

Herd Book	SP	
Birth date	2021-06-26	
Age	2.2 years	
Inbreeding	5.73%	
Birth Stat.	1	
AFL	ILP	EPI
15.9m	-	98
Lambd	1	
Lambs	1	
Weaned	1	

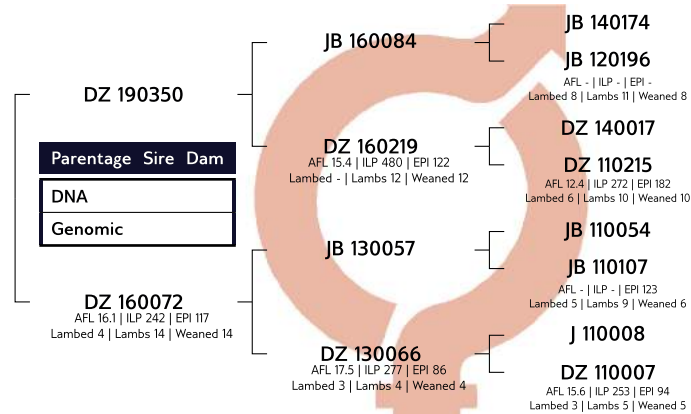

Growth			Reproduction			
Wn. Dir.	Wean Mat.	Post-Wn.	NLW	TWW	AFL	ILP
95	100	97	100	100	95	107
64%	58%	38%	46%	46%	46%	33%



EBV Analysis 2023-09-05

Logix Merit Index	99
Growth Index	99
Reproduction Index	102

SELLER REMARKS: Dragtig van Tyson DZ 21 0225.



HATARI DORMER VEILING

BE-HUMAN16 September 2023



LOT 47 (F)



DZ 220133

Kuddeboek	SP	
Geb. dtm	2022-06-28	
Oud.	1.2 jaar	
Inteling	7.43%	
Geb. Status	1	
OEL	ILP	OPI
-	-	-

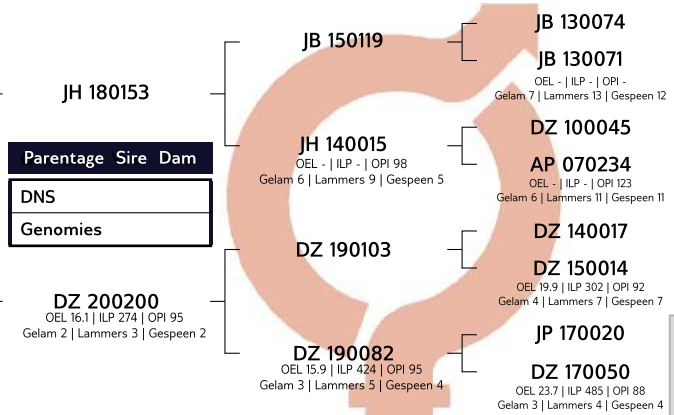

Growth			Reproduction			
Spn. Dir.	Spn. Mat.	Na-Spn.	GLS	TWW	OEL	ILP
90	94	91	107	107	86	108
58%	54%	46%	45%	45%	46%	35%



EBV Analyse 2023-09-05

Logix Meriete Indeks	94
Groei Indeks	90
Reproduksie Indeks	100

VERKOPER OPMERKINGS:Met lam van Tyson DZ 21 0225.

2 STEYNS BOERDERY
 Venterstad, Eastern Cape
 0824782470
 steyn1903@gmail.com



LOT 48 (F)



DZ 180050

Kuddeboek	SP	
Geb. dtm	2018-03-11	
Oud.	5.5 jaar	
Inteling	4.62%	
Geb. Status	1	
OEL	ILP	OPI
16.3m	595d	120
Gelam	3	
Lammers	11	
Gespeen	11	

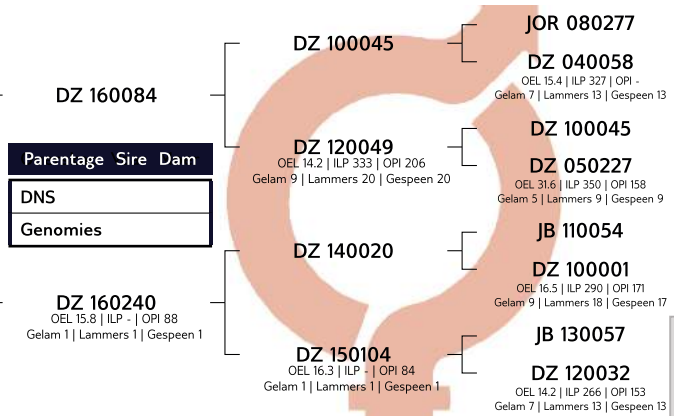

Growth			Reproduction			
Spn. Dir.	Spn. Mat.	Na-Spn.	GLS	TWW	OEL	ILP
104	89	104	108	108	78	103
70%	73%	38%	56%	56%	48%	39%



EBV Analyse 2023-09-05

Logix Meriete Indeks	102
Groei Indeks	101
Reproduksie Indeks	98

VERKOPER OPMERKINGS:Dragtig van Tyson DZ 21 0225.

2 STEYNS BOERDERY
 Venterstad, Eastern Cape
 0824782470
 steyn1903@gmail.com



LOT 49 (F)



P 220069

Kuddeboek	SP	
Geb. dtm	2022-05-01	
Oud.	1.4 jaar	
Inteling	5.74%	
Geb. Status	2	
OEL	ILP	OPI
-	-	-

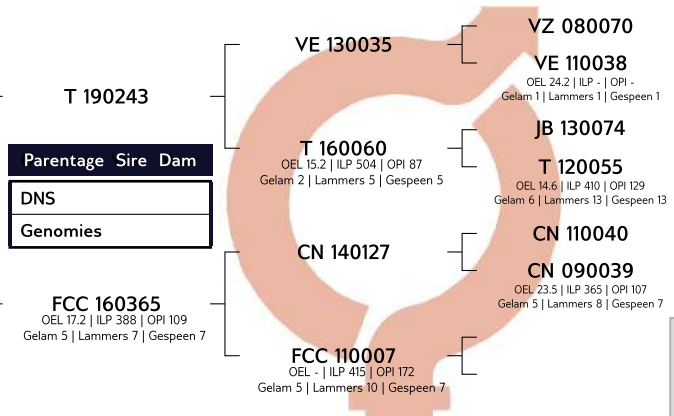

Growth			Reproduction			
Spn. Dir.	Spn. Mat.	Na-Spn.	GLS	TWW	OEL	ILP
93	113	93	93	93	129	92
63%	56%	48%	43%	43%	42%	30%



EBV Analyse 2023-09-05

Logix Meriete Indeks	104
Groei Indeks	103
Reproduksie Indeks	112

VERKOPER OPMERKINGS:Ranger Dogter. Dragtig met tweeling van P210001.

P. JORDAAN
 Somerset East, Eastern Cape
 0765130473
 bffarms01@gmail.com





HATARI DORMER VEILING

BE-HUMAN16 September 2023



LOT 50 (F)

P 220048



Herd Book	SP	
Birth date	2022-05-01	
Age	1.4 years	
Inbreeding	4.78%	
Birth Stat.	2	
AFL	ILP	EPI
-	-	-

P. JORDAAN

Somerset East, Eastern Cape
0765130473
bffarms01@gmail.com

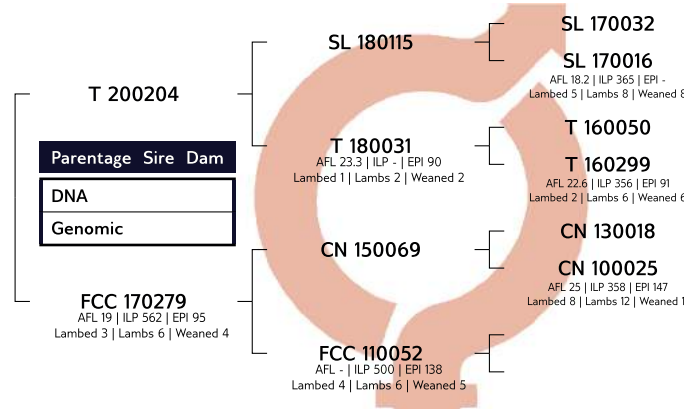

Growth			Reproduction			
Wn. Dir.	Wean Mat.	Post-Wn.	NLW	TWW	AFL	ILP
87	117	86	107	107	98	102
57%	42%	26%	30%	30%	28%	22%



EBV Analysis 2023-09-05

Logix Merit Index	103
Growth Index	99
Reproduction Index	117

SELLER REMARKS:Oop.

LOT 51 (F)

HE 220059



Herd Book	SP	
Birth date	2022-07-19	
Age	1.2 years	
Inbreeding	5.34%	
Birth Stat.	2	
AFL	ILP	EPI
-	-	-

EKSTEENS HATARI DORMER STUD

Bloemfontein, Free State
0825612917
mariusjnr@diysuper.co.za

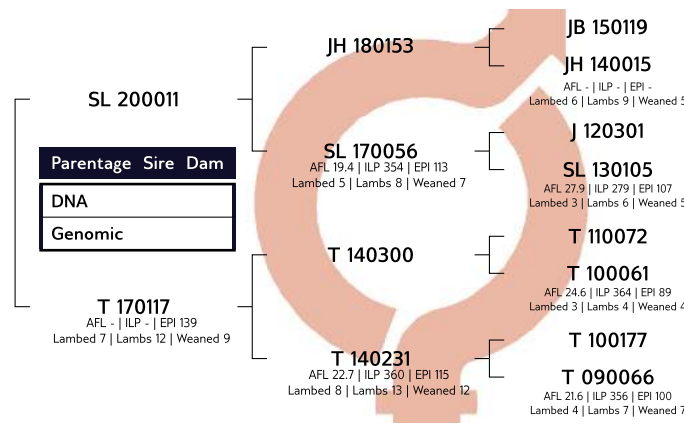

Growth			Reproduction			
Wn. Dir.	Wean Mat.	Post-Wn.	NLW	TWW	AFL	ILP
89	89	81	99	99	75	102
64%	53%	58%	39%	39%	37%	27%



EBV Analysis 2023-09-05

Logix Merit Index	84
Growth Index	87
Reproduction Index	85

SELLER REMARKS:Oop ooi. Kom saam met n Payback DZ190389 strooitjie.

LOT 52 (F)

HE 220083



Herd Book	SP	
Birth date	2022-08-08	
Age	1.1 years	
Inbreeding	8.16%	
Birth Stat.	2	
AFL	ILP	EPI
-	-	-

EKSTEENS HATARI DORMER STUD

Bloemfontein, Free State
0825612917
mariusjnr@diysuper.co.za

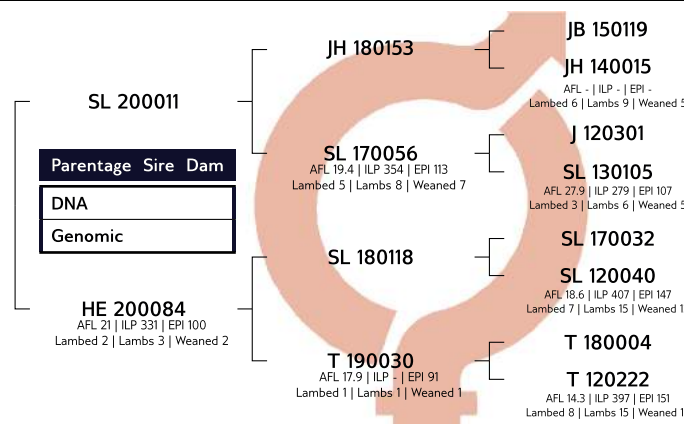

Growth			Reproduction			
Wn. Dir.	Wean Mat.	Post-Wn.	NLW	TWW	AFL	ILP
91	100	92	96	96	74	104
61%	47%	55%	35%	35%	34%	24%



EBV Analysis 2023-09-05

Logix Merit Index	89
Growth Index	94
Reproduction Index	90

SELLER REMARKS:Oop ooi. Kom saam met n Payback DZ190389 strooitjie.



HATARI DORMER VEILING

BE-HUMAN16 September 2023



LOT 53 (F)

HE 220090



Kuddeboek	SP	
Geb. dtm	2022-08-12	
Oud.	1.1 jaar	
Inteling	5.96%	
Geb. Status	2	
OEL	ILP	OPI
-	-	-

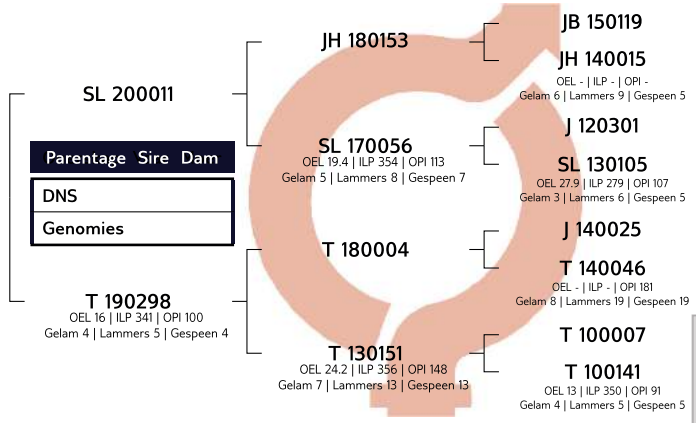

Growth			Reproduction			
Spn. Dir.	Spn. Mat.	Na-Spn.	GLS	TWW	OEL	ILP
92	105	92	99	99	84	110
62%	51%	58%	38%	38%	37%	26%



EBV Analise 2023-09-05

Logix Meriete Indeks	95
Groei Indeks	97
Reproduksie Indeks	100

EKSTEENS HATARI DORMER STUD
 Bloemfontein, Free State
 0825612917
 mariusjnr@diysuper.co.za



VERKOPER OPMERKINGS:Oop ooi. Kom saam met n Payback DZ190389 strooitjie.

LOT 54 (F)

HE 220092



Kuddeboek	SP	
Geb. dtm	2022-08-12	
Oud.	1.1 jaar	
Inteling	5.96%	
Geb. Status	2	
OEL	ILP	OPI
-	-	-

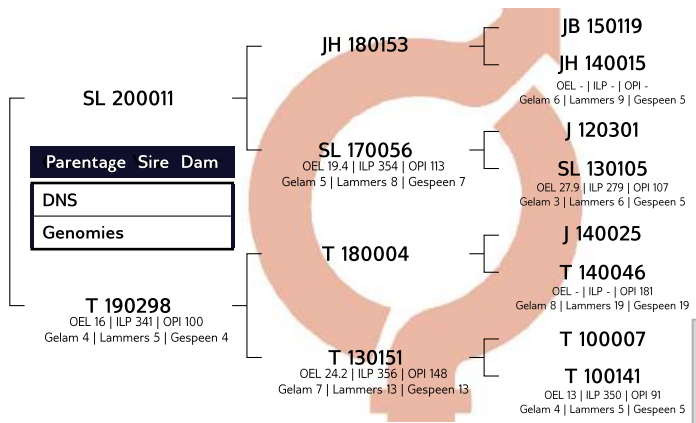

Growth			Reproduction			
Spn. Dir.	Spn. Mat.	Na-Spn.	GLS	TWW	OEL	ILP
94	104	94	99	99	84	110
62%	51%	58%	38%	38%	37%	26%



EBV Analise 2023-09-05

Logix Meriete Indeks	97
Groei Indeks	99
Reproduksie Indeks	100

EKSTEENS HATARI DORMER STUD
 Bloemfontein, Free State
 0825612917
 mariusjnr@diysuper.co.za



VERKOPER OPMERKINGS:Oop ooi. Kom saam met n Payback DZ190389 strooitjie.

LOT 55 (F)

HE 220112

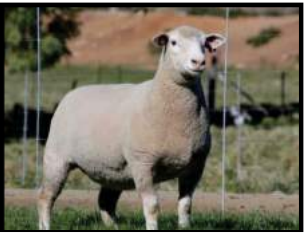

Kuddeboek	SP	
Geb. dtm	2022-08-10	
Oud.	1.1 jaar	
Inteling	4.42%	
Geb. Status	2	
OEL	ILP	OPI
-	-	-

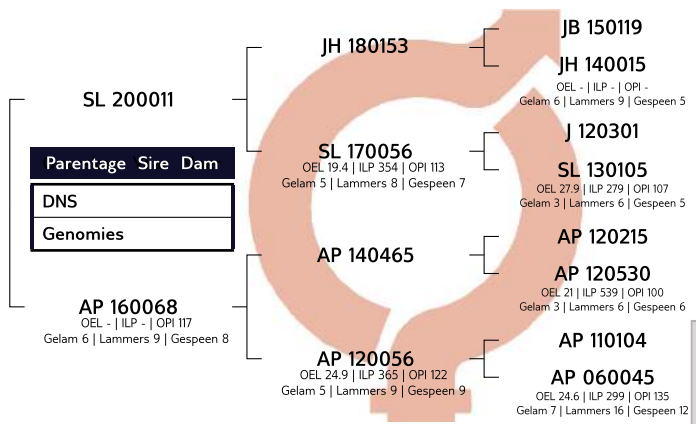

Growth			Reproduction			
Spn. Dir.	Spn. Mat.	Na-Spn.	GLS	TWW	OEL	ILP
98	108	110	108	108	90	95
63%	52%	60%	38%	38%	36%	25%



EBV Analise 2023-09-05

Logix Meriete Indeks	106
Groei Indeks	105
Reproduksie Indeks	111

EKSTEENS HATARI DORMER STUD
 Bloemfontein, Free State
 0825612917
 mariusjnr@diysuper.co.za



VERKOPER OPMERKINGS:Oop ooi. Kom saam met n Payback DZ190389 strooitjie.



HATARI DORMER VEILING

BE-HUMAN16 September 2023



LOT 56 (F)



TWEE BROERS DORMER STOET

Barkly East, Eastern Cape
0723132232
tjaart@barkly.co.za



T 210174

Herd Book	SP	
Birth date	2021-05-10	
Age	2.4 years	
Inbreeding	12.46%	
Birth Stat.	2	
AFL	ILP	EPI
16.7m	-	95
Lambled	1	
Lambs	1	
Weaned	1	

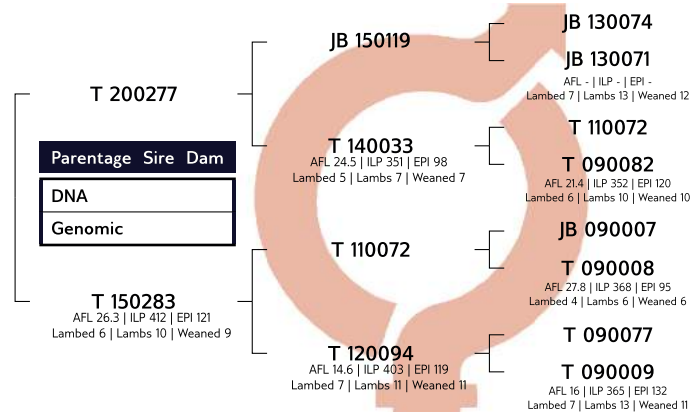

Growth			Reproduction			
Wn. Dir.	Wean Mat.	Post-Wn.	NLW	TWW	AFL	ILP
94	93	94	92	92	112	64
59%	55%	26%	43%	43%	40%	29%



EBV Analysis 2023-09-05

Logix Merit Index	90
Growth Index	93
Reproduction Index	91

SELLER REMARKS: Dragtig met tweeling van Topgun T21 0095.

LOT 57 (F)



TWEE BROERS DORMER STOET

Barkly East, Eastern Cape
0723132232
tjaart@barkly.co.za



T 200002

Herd Book	SP	
Birth date	2020-05-10	
Age	3.4 years	
Inbreeding	3.99%	
Birth Stat.	2	
AFL	ILP	EPI
35.6m	-	95
Lambled	1	
Lambs	2	
Weaned	0	

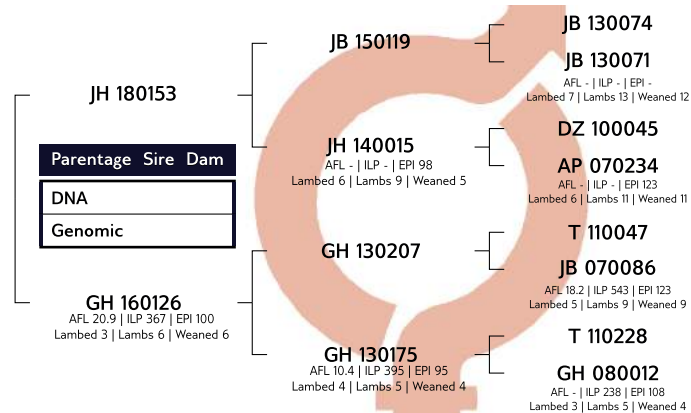

Growth			Reproduction			
Wn. Dir.	Wean Mat.	Post-Wn.	NLW	TWW	AFL	ILP
76	98	78	106	106	69	119
64%	59%	42%	50%	50%	51%	36%



EBV Analysis 2023-09-05

Logix Merit Index	81
Growth Index	78
Reproduction Index	94

SELLER REMARKS: Dragtig met tweeling van Topgun T21 0095.

LOT 58 (F)



TWEE BROERS DORMER STOET

Barkly East, Eastern Cape
0723132232
tjaart@barkly.co.za



T 220138

Herd Book	SP	
Birth date	2022-05-01	
Age	1.4 years	
Inbreeding	5.36%	
Birth Stat.	2	
AFL	ILP	EPI
-	-	-

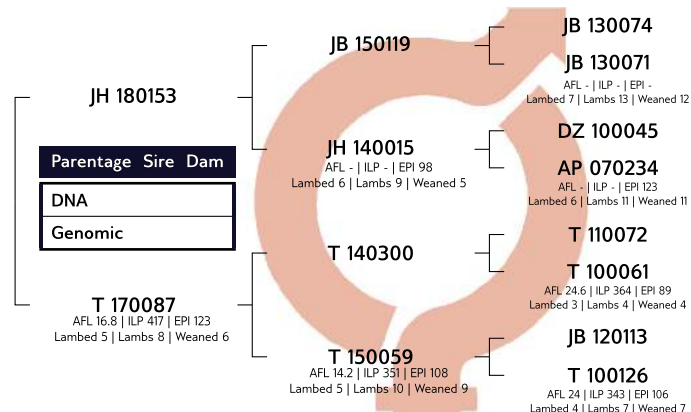

Growth			Reproduction			
Wn. Dir.	Wean Mat.	Post-Wn.	NLW	TWW	AFL	ILP
83	96	83	108	108	81	96
64%	59%	44%	49%	49%	47%	36%



EBV Analysis 2023-09-05

Logix Merit Index	87
Growth Index	84
Reproduction Index	98

SELLER REMARKS: Met ooi lam nr.600. Vaar is Topgun T210095.



HATARI DORMER VEILING

BE-HUMAN16 September 2023



LOT 59 (F)

SL 220083



Kuddeboek	SP	
Geb. dtm	2022-09-11	
Oud.	1 jaar	
Inteling	8.93%	
Geb. Status	1	
OEL	ILP	OPI
-	-	-

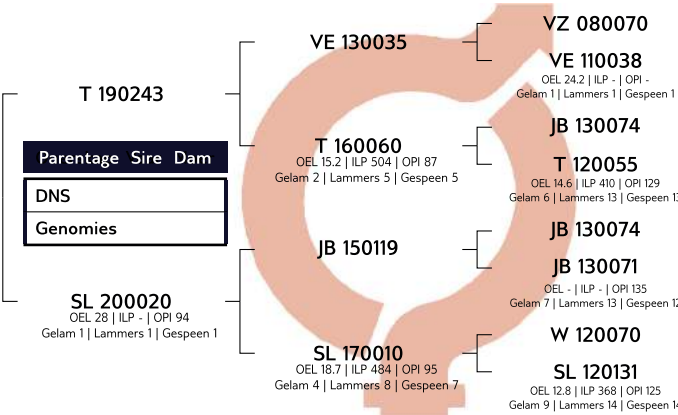

Growth			Reproduction			
Spn. Dir.	Spn. Mat.	Na-Spn.	GLS	TWW	OEL	ILP
100	95	100	100	100	112	88
62%	53%	45%	42%	42%	44%	31%



EBV Analise 2023-09-05

Logix Meriete Indeks	102
Groei Indeks	100
Reproduksie Indeks	102

ROOIEK DORMERS
Barkley East, Eastern Cape
0723132232
tjaart@barkly.co.za

VERKOPER OPMERKINGS:Met ooi lam nr.600. Vaar is Topgun T210095.

LOT 60 (F)

SL 220060



Kuddeboek	SP	
Geb. dtm	2022-09-11	
Oud.	1 jaar	
Inteling	8.62%	
Geb. Status	1	
OEL	ILP	OPI
-	-	-

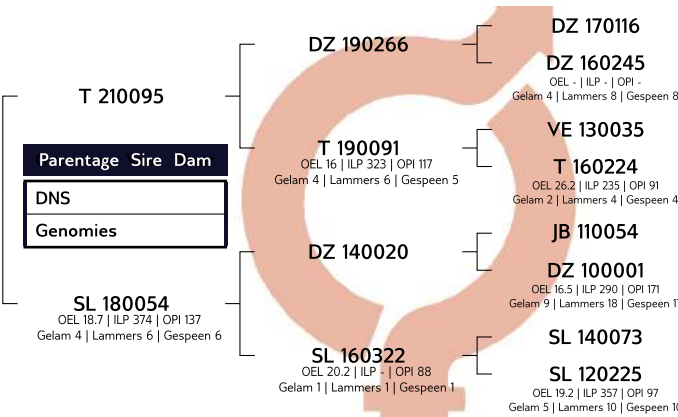

Growth			Reproduction			
Spn. Dir.	Spn. Mat.	Na-Spn.	GLS	TWW	OEL	ILP
98	109	98	94	94	100	93
59%	45%	30%	35%	35%	33%	27%



EBV Analise 2023-09-05

Logix Meriete Indeks	101
Groei Indeks	105
Reproduksie Indeks	103

ROOIEK DORMERS
Barkley East, Eastern Cape
0723132232
tjaart@barkly.co.za

VERKOPER OPMERKINGS:Dragtig met tweeling van Topgun T21 0095.

LOT 61 (F)

DZ 210270



Kuddeboek	SP	
Geb. dtm	2021-06-29	
Oud.	2.2 jaar	
Inteling	7.59%	
Geb. Status	2	
OEL	ILP	OPI
15.8m	-	98
Gelam	Lammers	Gespeen
1	1	1

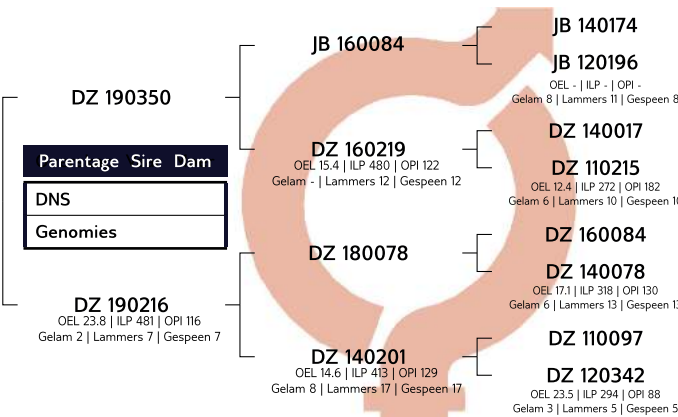

Growth			Reproduction			
Spn. Dir.	Spn. Mat.	Na-Spn.	GLS	TWW	OEL	ILP
108	99	104	97	97	90	110
63%	56%	35%	42%	42%	43%	30%



EBV Analise 2023-09-05

Logix Meriete Indeks	107
Groei Indeks	111
Reproduksie Indeks	100

2 STEYNS BOERDERY
Venterstad, Eastern Cape
0824782470
steyni903@gmail.com



VERKOPER OPMERKINGS:Dragtig van Tyson DZ 21 0225.



HATARI DORMER VEILING

BE-HUMAN16 September 2023



LOT 62 (F)



2 STEYNS BOERDERY
Venterstad, Eastern Cape
0824782470
steyn1903@gmail.com



DZ 200006

Herd Book	SP	
Birth date	2020-02-27	
Age	3.5 years	
Inbreeding	8.92%	
Birth Stat.	2	
AFL	ILP	EPI
16m	482d	101
Lambled	2	
Lambs	4	
Weaned	4	

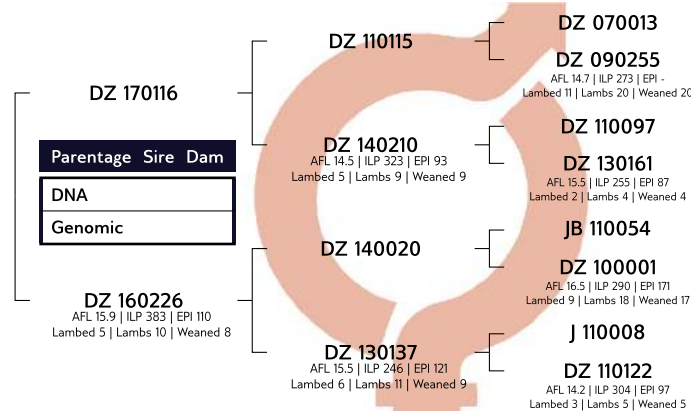

Growth			Reproduction			
Wn. Dir.	Wean Mat.	Post-Wn.	NLW	TWW	AFL	ILP
108	86	101	115	115	108	93
68%	69%	48%	55%	55%	52%	42%



EBV Analysis 2023-09-05

Logix Merit Index	113
Growth Index	104
Reproduction Index	110

SELLER REMARKS:Met tweeling lammers van Tyson DZ 21 0225.

LOT 63 (F)



2 STEYNS BOERDERY
Venterstad, Eastern Cape
0824782470
steyn1903@gmail.com



DZ 220249

Herd Book	SP	
Birth date	2022-07-02	
Age	1.2 years	
Inbreeding	8.29%	
Birth Stat.	3	
AFL	ILP	EPI
-	-	-

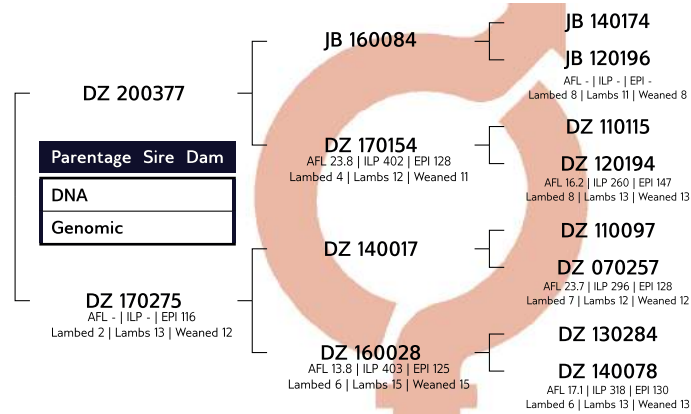

Growth			Reproduction			
Wn. Dir.	Wean Mat.	Post-Wn.	NLW	TWW	AFL	ILP
93	96	92	111	111	104	102
59%	50%	39%	42%	42%	39%	34%



EBV Analysis 2023-09-05

Logix Merit Index	102
Growth Index	94
Reproduction Index	110

SELLER REMARKS:Dragtig van Tyson DZ 21 0225.

LOT 64 (F)



2 STEYNS BOERDERY
Venterstad, Eastern Cape
0824782470
steyn1903@gmail.com



DZ 170265

Herd Book	SP	
Birth date	2017-11-10	
Age	5.8 years	
Inbreeding	8.26%	
Birth Stat.	2	
AFL	ILP	EPI
15.7m	661d	102
Lambled	2	
Lambs	7	
Weaned	7	

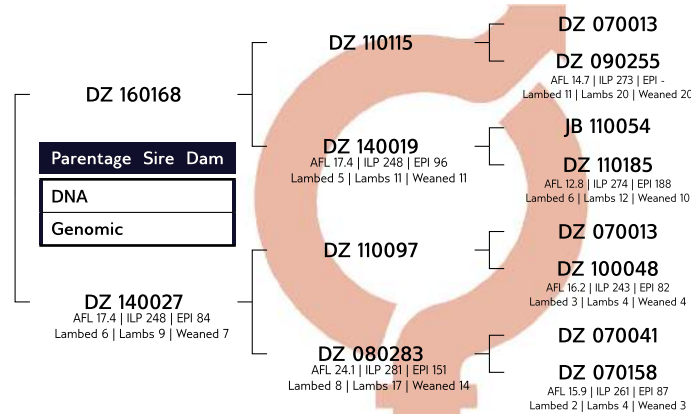

Growth			Reproduction			
Wn. Dir.	Wean Mat.	Post-Wn.	NLW	TWW	AFL	ILP
102	100	101	101	101	95	73
66%	70%	37%	52%	52%	43%	36%



EBV Analysis 2023-09-05

Logix Merit Index	101
Growth Index	105
Reproduction Index	100

SELLER REMARKS:Met lam van DZ 21 0355.

LOT 65 (F)



2 STEYNS BOERDERY
 Venterstad, Eastern Cape
 0824782470
 steyn1903@gmail.com



DZ 220248

Kuddeboek	SP	
Geb. dtm	2022-07-02	
Oud.	1.2 jaar	
Inteling	5.42%	
Geb. Status	3	
OEL	ILP	OPI
-	-	-

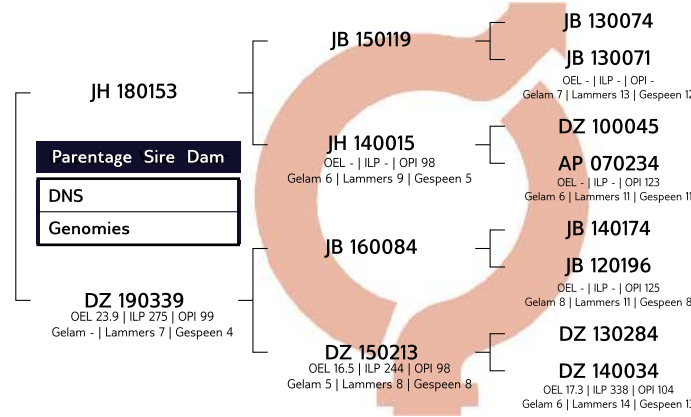

Growth			Reproduction			
Spn. Dir.	Spn. Mat.	Na-Spn.	GLS	TWW	OEL	ILP
97	97	97	101	101	83	102
64%	59%	48%	50%	50%	49%	38%



EBV Analise 2023-09-05

Logix Meriete Indeks	97
Groei Indeks	99
Reproduksie Indeks	97

VERKOPER OPMERKINGS: Met tweeling lammers van Tyson DZ 21 0225.

LOT 66 (F)



EKSTEENS HATARI DORMER STUD
 Bloemfontein, Free State
 0825612917
 mariusjnr@diysuper.co.za



HE 220113

Kuddeboek	SP	
Geb. dtm	2022-08-12	
Oud.	1.1 jaar	
Inteling	6.61%	
Geb. Status	2	
OEL	ILP	OPI
-	-	-

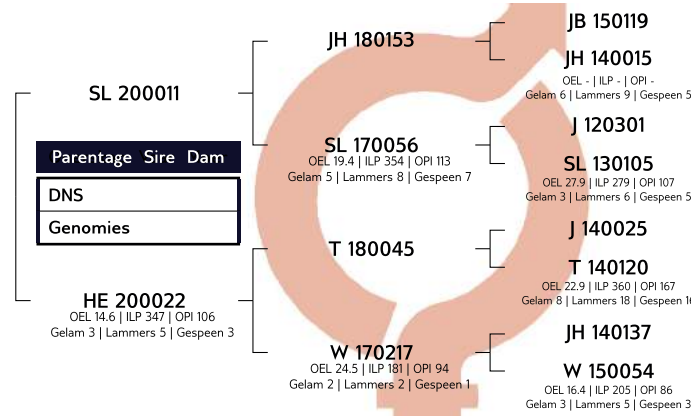

Growth			Reproduction			
Spn. Dir.	Spn. Mat.	Na-Spn.	GLS	TWW	OEL	ILP
103	99	99	102	102	77	111
60%	48%	56%	36%	36%	34%	25%



EBV Analise 2023-09-05

Logix Meriete Indeks	103
Groei Indeks	106
Reproduksie Indeks	99

VERKOPER OPMERKINGS: Oop ooi. Kom saam met n Payback DZ190389 strooitjie.

LOT 67 (F)



EKSTEENS HATARI DORMER STUD
 Bloemfontein, Free State
 0825612917
 mariusjnr@diysuper.co.za



HE 220122

Kuddeboek	SP	
Geb. dtm	2022-08-13	
Oud.	1.1 jaar	
Inteling	5.96%	
Geb. Status	2	
OEL	ILP	OPI
-	-	-

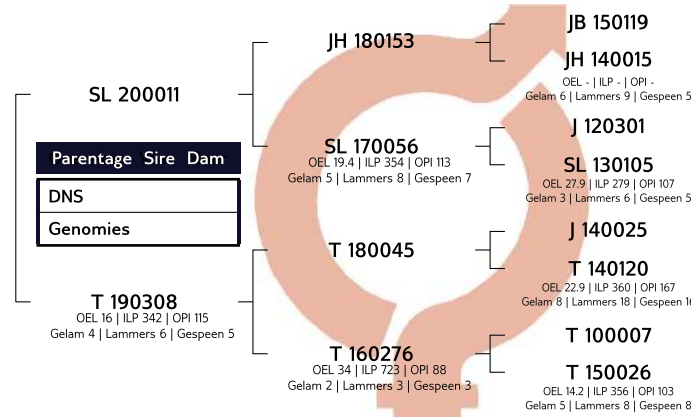

Growth			Reproduction			
Spn. Dir.	Spn. Mat.	Na-Spn.	GLS	TWW	OEL	ILP
101	101	99	99	99	84	108
62%	51%	56%	38%	38%	36%	27%



EBV Analise 2023-09-05

Logix Meriete Indeks	101
Groei Indeks	104
Reproduksie Indeks	99

VERKOPER OPMERKINGS: Oop ooi. Kom saam met n Payback DZ190389 strooitjie.



HATARI DORMER VEILING

BE-HUMAN16 September 2023



LOT 68 (F)



HE 220129

Herd Book	SP	
Birth date	2022-08-09	
Age	1.1 years	
Inbreeding	5.1%	
Birth Stat.	2	
AFL	ILP	EPI
-	-	-

EKSTEENS HATARI DORMER STUD

Bloemfontein, Free State
0825612917
mariusjnr@diysuper.co.za

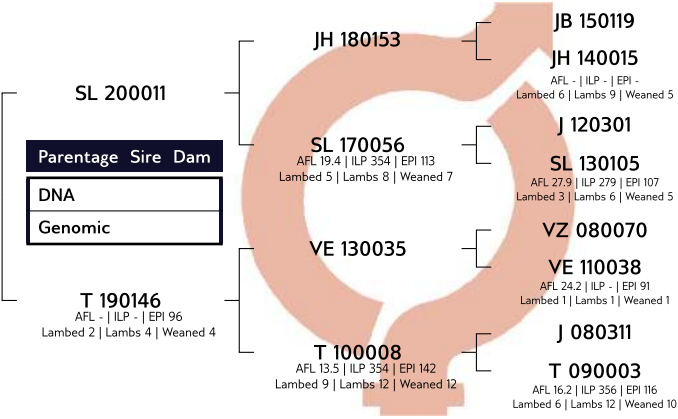

Growth			Reproduction			
Wn. Dir.	Wean Mat.	Post-Wn.	NLW	TWW	AFL	ILP
96	93	96	105	105	93	98
62%	50%	57%	37%	37%	37%	27%



EBV Analysis 2023-09-05

Logix Merit Index	98
Growth Index	96
Reproduction Index	100

SELLER REMARKS: Oop ooi. Kom saam met n Payback DZ190389 strooitjie.

LOT 69 (F)



HE 220145

Herd Book	SP	
Birth date	2022-08-24	
Age	1.1 years	
Inbreeding	5.7%	
Birth Stat.	2	
AFL	ILP	EPI
-	-	-

EKSTEENS HATARI DORMER STUD

Bloemfontein, Free State
0825612917
mariusjnr@diysuper.co.za

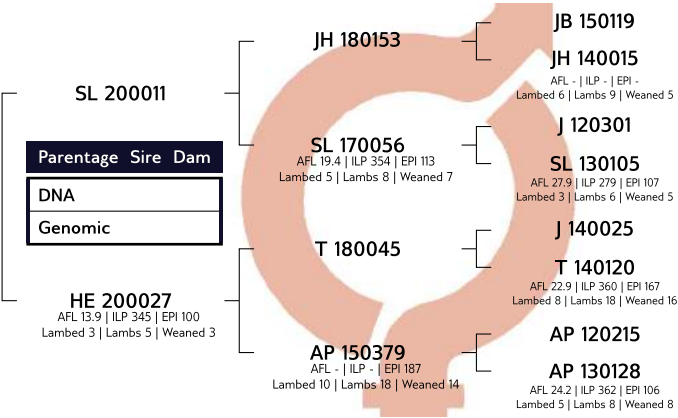

Growth			Reproduction			
Wn. Dir.	Wean Mat.	Post-Wn.	NLW	TWW	AFL	ILP
106	98	105	101	101	90	108
61%	49%	56%	38%	38%	35%	26%



EBV Analysis 2023-09-05

Logix Merit Index	107
Growth Index	108
Reproduction Index	102

SELLER REMARKS: Oop ooi. Kom saam met n Payback DZ190389 strooitjie.

LOT 70 (F)



HE 220159

Herd Book	SP	
Birth date	2022-08-29	
Age	1.1 years	
Inbreeding	5.2%	
Birth Stat.	2	
AFL	ILP	EPI
-	-	-

EKSTEENS HATARI DORMER STUD

Bloemfontein, Free State
0825612917
mariusjnr@diysuper.co.za

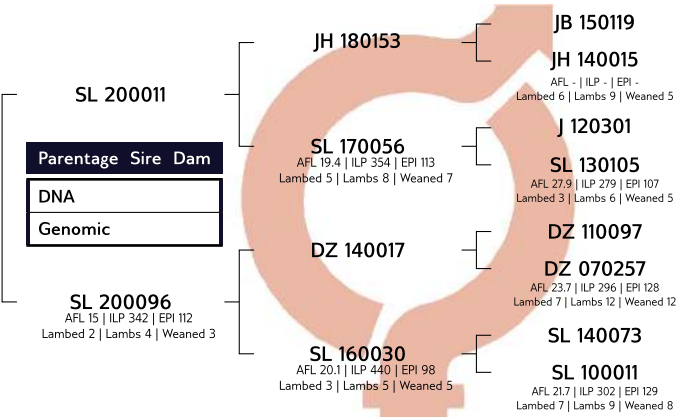

Growth			Reproduction			
Wn. Dir.	Wean Mat.	Post-Wn.	NLW	TWW	AFL	ILP
103	100	102	106	106	90	107
62%	51%	58%	39%	39%	38%	29%



EBV Analysis 2023-09-05

Logix Merit Index	108
Growth Index	106
Reproduction Index	106

SELLER REMARKS: Oop ooi. Kom saam met n Payback DZ190389 strooitjie.

LOT 71 (F)



2 STEYNS BOERDERY
 Venterstad, Eastern Cape
 0824782470
 steyn1903@gmail.com



DZ 180023

Kuddeboek	SP	
Geb. dtm	2018-03-10	
Oud.	5.5 jaar	
Inteling	5.65%	
Geb. Status	3	
OEL	ILP	OPI
15.9m	723d	104
Gelam	2	
Lammers	8	
Gespeen	8	

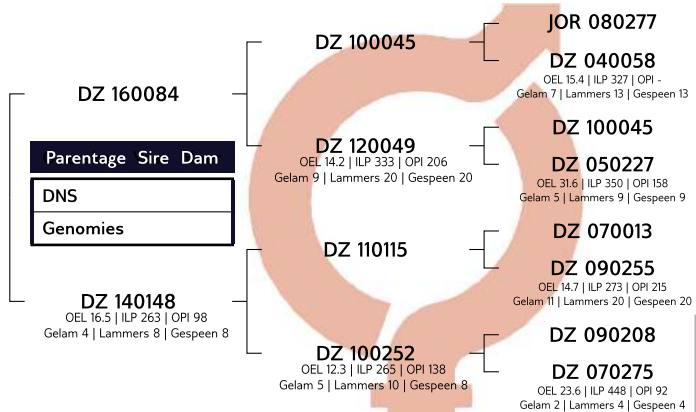

Growth			Reproduction			
Spn. Dir.	Spn. Mat.	Na-Spn.	GLS	TWW	OEL	ILP
105	89	100	106	106	104	111
70%	73%	39%	57%	57%	49%	41%



EBV Analise 2023-09-05

Logix Meriete Indeks	107
Groei Indeks	102
Reproduksie Indeks	105

VERKOPER OPMERKINGS: Dragtig van Tyson DZ 21 0225.

LOT 72 (F)



2 STEYNS BOERDERY
 Venterstad, Eastern Cape
 0824782470
 steyn1903@gmail.com



DZ 180030

Kuddeboek	SP	
Geb. dtm	2018-03-10	
Oud.	5.5 jaar	
Inteling	3.98%	
Geb. Status	3	
OEL	ILP	OPI
15.9m	602d	107
Gelam	3	
Lammers	8	
Gespeen	8	

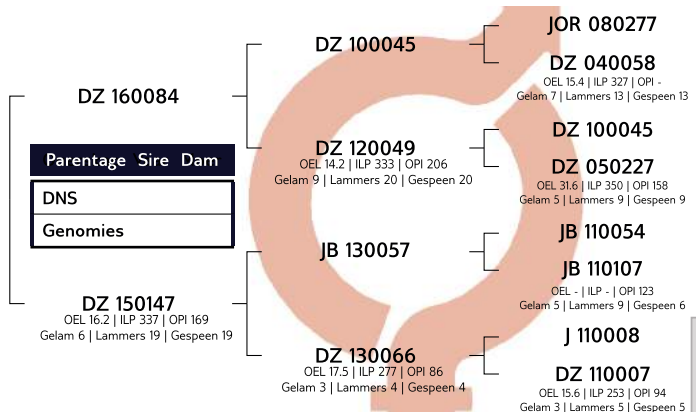

Growth			Reproduction			
Spn. Dir.	Spn. Mat.	Na-Spn.	GLS	TWW	OEL	ILP
99	91	100	108	108	91	108
71%	74%	37%	59%	59%	48%	40%



EBV Analise 2023-09-05

Logix Meriete Indeks	101
Groei Indeks	97
Reproduksie Indeks	102

VERKOPER OPMERKINGS: Dragtig van DZ 21 0355.

LOT 73 (F)



2 STEYNS BOERDERY
 Venterstad, Eastern Cape
 0824782470
 steyn1903@gmail.com



DZ 220267

Kuddeboek	SP	
Geb. dtm	2022-07-18	
Oud.	1.2 jaar	
Inteling	6.5%	
Geb. Status	2	
OEL	ILP	OPI
-	-	-

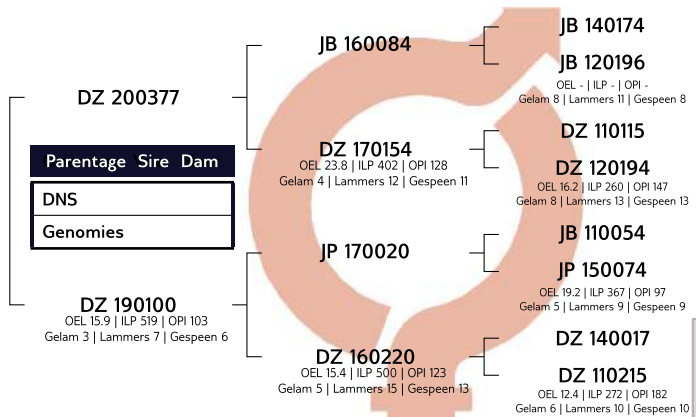

Growth			Reproduction			
Spn. Dir.	Spn. Mat.	Na-Spn.	GLS	TWW	OEL	ILP
83	105	87	98	98	101	115
58%	48%	37%	40%	40%	37%	32%



EBV Analise 2023-09-05

Logix Meriete Indeks	92
Groei Indeks	89
Reproduksie Indeks	103

VERKOPER OPMERKINGS: Met tweeling lammers van Tyson DZ 21 0225.



HATARI DORMER VEILING

BE-HUMAN16 September 2023



LOT 74 (F)



2 STEYNS BOERDERY

Venterstad, Eastern Cape
0824782470
steyn1903@gmail.com



DZ 220283

Herd Book	SP	
Birth date	2022-07-19	
Age	1.2 years	
Inbreeding	7.89%	
Birth Stat.	2	
AFL	ILP	EPI
-	-	-

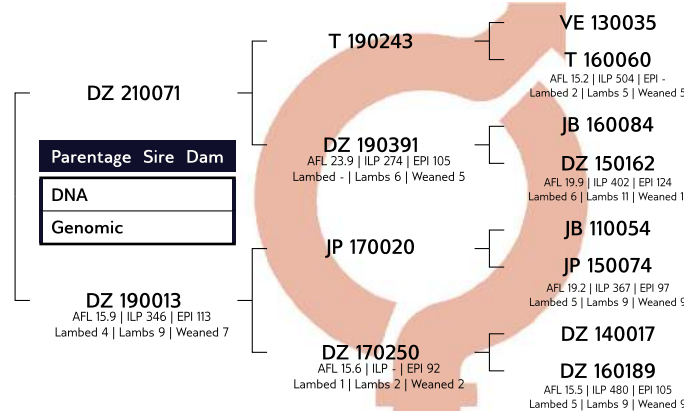

Growth			Reproduction			
Wn. Dir.	Wean Mat.	Post-Wn.	NLW	TWW	AFL	ILP
105	103	105	107	107	107	107
60%	47%	32%	36%	36%	34%	27%



EBV Analysis 2023-09-05

Logix Merit Index	115
Growth Index	110
Reproduction Index	115

SELLER REMARKS:Met tweeling lammers van Tyson DZ 21 0225.

LOT 75 (F)



2 STEYNS BOERDERY

Venterstad, Eastern Cape
0824782470
steyn1903@gmail.com



DZ 220167

Herd Book	SP	
Birth date	2022-06-30	
Age	1.2 years	
Inbreeding	5.48%	
Birth Stat.	2	
AFL	ILP	EPI
-	-	-

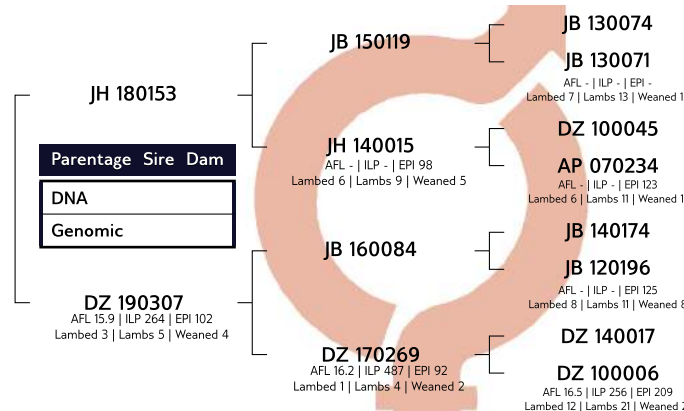

Growth			Reproduction			
Wn. Dir.	Wean Mat.	Post-Wn.	NLW	TWW	AFL	ILP
100	100	98	96	96	80	102
64%	58%	49%	50%	50%	50%	39%



EBV Analysis 2023-09-05

Logix Merit Index	97
Growth Index	103
Reproduction Index	93

SELLER REMARKS:Met lam van Tyson DZ 21 0225.

LOT 76 (F)



2 STEYNS BOERDERY

Venterstad, Eastern Cape
0824782470
steyn1903@gmail.com



DZ 220215

Herd Book	SP	
Birth date	2022-07-01	
Age	1.2 years	
Inbreeding	9.15%	
Birth Stat.	2	
AFL	ILP	EPI
-	-	-

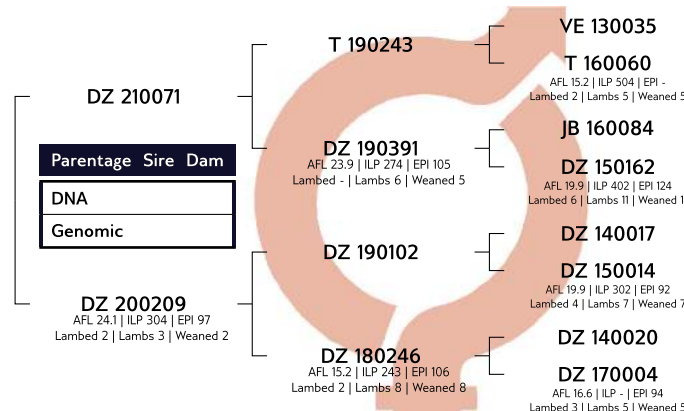

Growth			Reproduction			
Wn. Dir.	Wean Mat.	Post-Wn.	NLW	TWW	AFL	ILP
105	108	106	105	105	105	84
53%	41%	31%	32%	32%	30%	26%



EBV Analysis 2023-09-05

Logix Merit Index	112
Growth Index	112
Reproduction Index	113

SELLER REMARKS:Met lam van Tyson DZ 21 0225.

LOT 77 (F)

DZ 200360



Kuddeboek	SP	
Geb. dtm	2020-10-30	
Oud.	2.9 jaar	
Inteling	4.79%	
Geb. Status	1	
OEL	ILP	OPI
-	-	98

2 STEYNS BOERDERY

Venterstad, Eastern Cape
0824782470
steyn1903@gmail.com

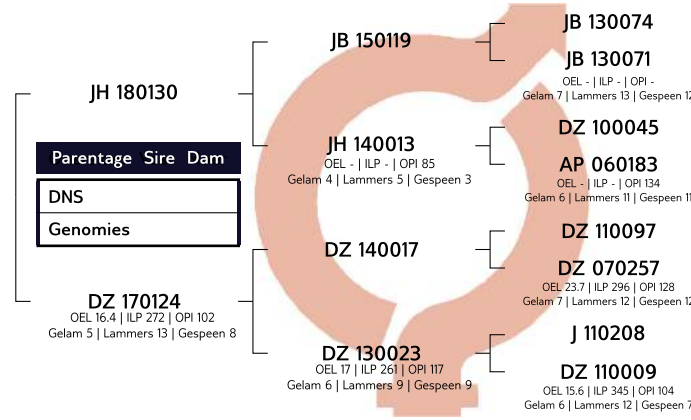

Growth			Reproduction			
Spn. Dir.	Spn. Mat.	Na-Spn.	GLS	TWW	OEL	ILP
108	102	104	87	87	113	90
64%	57%	45%	44%	44%	42%	32%



EBV Analise 2023-09-05

Logix Meriete Indeks **106**

Groei Indeks **112**

Reproduksie Indeks **99**

VERKOPER OPMERKINGS: Dragtig van Tyson DZ 21 0225.

LOT 78 (F)

DZ 200383



Kuddeboek	SP	
Geb. dtm	2020-11-01	
Oud.	2.9 jaar	
Inteling	7.89%	
Geb. Status	2	
OEL	ILP	OPI
15.8m	240d	103
Gelam	1	
Lammers	2	
Gespeen	2	

2 STEYNS BOERDERY

Venterstad, Eastern Cape
0824782470
steyn1903@gmail.com

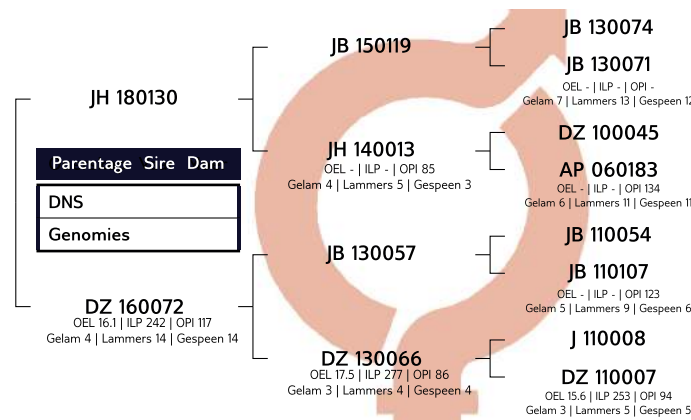

Growth			Reproduction			
Spn. Dir.	Spn. Mat.	Na-Spn.	GLS	TWW	OEL	ILP
104	91	105	89	89	95	88
66%	61%	44%	46%	46%	42%	35%



EBV Analise 2023-09-05

Logix Meriete Indeks **95**

Groei Indeks **103**

Reproduksie Indeks **87**

VERKOPER OPMERKINGS: Dragtig van Tyson DZ 21 0225.

LOT 79 (F)

DZ 180395



Kuddeboek	SP	
Geb. dtm	2018-11-18	
Oud.	4.8 jaar	
Inteling	7.41%	
Geb. Status	2	
OEL	ILP	OPI
15.3m	484d	100
Gelam	3	
Lammers	6	
Gespeen	6	

2 STEYNS BOERDERY

Venterstad, Eastern Cape
0824782470
steyn1903@gmail.com

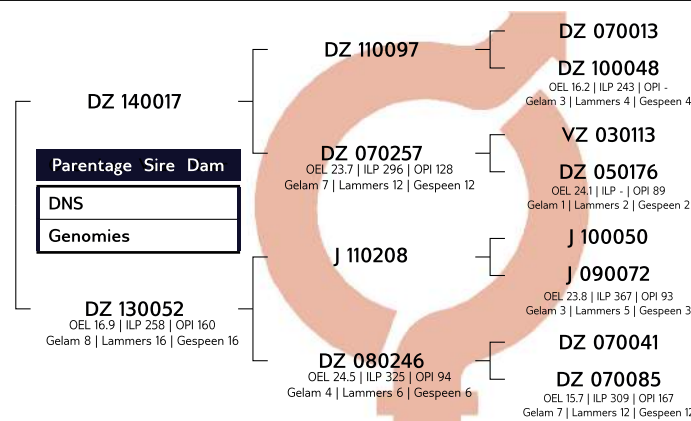

Growth			Reproduction			
Spn. Dir.	Spn. Mat.	Na-Spn.	GLS	TWW	OEL	ILP
95	87	90	102	102	135	82
69%	73%	49%	61%	61%	52%	46%



EBV Analise 2023-09-05

Logix Meriete Indeks **100**

Groei Indeks **92**

Reproduksie Indeks **105**

VERKOPER OPMERKINGS: Dragtig van Tyson DZ 21 0225.



HATARI DORMER VEILING

BE-HUMAN16 September 2023



LOT 80 (F)

DZ 210390



• Herd Book	SP	
Birth date	2021-10-30	
Age	1.9 years	
Inbreeding	18.01%	
Birth Stat.	1	
AFL	ILP	EPI
-	-	-

2 STEYNS BOERDERY

Venterstad, Eastern Cape
0824782470
steyn1903@gmail.com

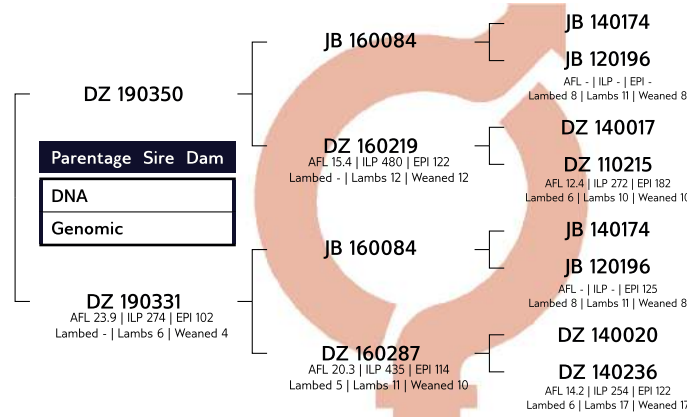

Growth			Reproduction			
Wn. Dir.	Wean Mat.	Post-Wn.	NLW	TWW	AFL	ILP
103	103	100	92	92	98	97
62%	51%	41%	42%	42%	43%	35%



EBV Analysis 2023-09-05

Logix Merit Index	101
Growth Index	107
Reproduction Index	97

SELLER REMARKS: Dragtig van Tyson DZ 21 0225.

KOMMERSIËLE OOIE

LOT	DIER ID	PAKKIE GROOTE	OPMERKING
83	GRASKAROO KOMMERSIËLE OOIE	10 OOIE PER PAKKIE	WISSEL 2 TAND OOIE
84	TWEE BROERS KOMMERSIËLE OOIE	10 OOIE EN 10 LAMMERS	
85	GRASKAROO KOMMERSIËLE OOIE	10 OOIE PER PAKKIE	WISSEL 2 TAND OOIE
86	TWEE BROERS KOMMERSIËLE OOIE	10 OOIE EN 10 LAMMERS	
87	GRASKAROO KOMMERSIËLE OOIE	10 OOIE PER PAKKIE	WISSEL 2 TAND OOIE
88	TWEE BROERS KOMMERSIËLE OOIE	3 OOIE EN 3 LAMMERS	
89	GRASKAROO KOMMERSIËLE OOIE	10 OOIE PER PAKKIE	WISSEL 2 TAND OOIE
90	TWEE BROERS KOMMERSIËLE OOIE	6 OOIE EN 12 LAMMERS	
91	GRASKAROO KOMMERSIËLE OOIE	10 OOIE PER PAKKIE	WISSEL 2 TAND OOIE
92	TWEE BROERS KOMMERSIËLE OOIE	10 OOIE PER PAKKIE	
93	GRASKAROO KOMMERSIËLE OOIE	10 OOIE PER PAKKIE	WISSEL 2 TAND OOIE
94	TWEE BROERS KOMMERSIËLE OOIE	10 OOIE PER PAKKIE	
95	GRASKAROO KOMMERSIËLE OOIE	10 OOIE PER PAKKIE	WISSEL 2 TAND OOIE
96	TWEE BROERS KOMMERSIËLE OOIE	10 OOIE PER PAKKIE	
97	GRASKAROO KOMMERSIËLE OOIE	10 OOIE PER PAKKIE	WISSEL 2 TAND OOIE
98	TWEE BROERS KOMMERSIËLE OOIE	10 OOIE PER PAKKIE	
99	GRASKAROO KOMMERSIËLE OOIE	10 OOIE PER PAKKIE	WISSEL 2 TAND OOIE
100	TWEE BROERS KOMMERSIËLE OOIE	10 OOIE PER PAKKIE	
101	GRASKAROO KOMMERSIËLE OOIE	10 OOIE PER PAKKIE	WISSEL 2 TAND OOIE
102	TWEE BROERS KOMMERSIËLE OOIE	10 OOIE PER PAKKIE	
103	TWEE BROERS KOMMERSIËLE OOIE	10 OOIE PER PAKKIE	

RULES OF AUCTION, TERMS AND CONDITIONS

1. This auction will be held under the control of BKB Limited/ BKB van Wyk (Pty) Limited/ BKB Louwid (Pty) Limited (hereinafter referred to as the Auctioneer) with business premises situated at: 15 Church street Cradock.
2. The Auctioneer is hereby appointed by the Purchaser and Seller to act for and on behalf of the Purchaser and Seller as agent in accordance with Section 54 of the Value-Added Tax Act, 1991, in respect of all tax invoices, credit and/or debit notes in respect of all livestock, game and/or goods offered at the auction or any costs of transport and insurances premiums paid for on behalf of the Purchaser and Seller.
3. The rules of this auction shall comply with the provisions of Section 45 and all relevant regulations to the Consumer Protection Act 68 of 2008.
4. For greater clarity Section 45(1-4) states as follows:
 - 4.1. In this section, auction includes a sale in execution of or pursuant to a court order, to the extent that the order contemplates that the sale is to be conducted by an auction.
 - 4.2. When goods are put up for sale by auction, each lot is, unless there is evidence to the contrary, regarded to be the subject of a separate transaction.
 - 4.3. A sale by auction is complete when the auctioneer announces its completion by the fall of the hammer, or in any other customary manner, and until that announcement is made, a bid may be retracted.
 - 4.4. Notice must be given in advance that a lot or sale by auction is subject to:
 - 4.4.1. A reserved or upset price; or
 - 4.4.2. A right to bid by or on behalf of the owner or auctioneer, in which case the owner or auctioneer, or any one person on behalf of the owner or auctioneer, as the case may be, may bid at the auction.
5. Until the fall of the hammer as contemplated in Section 45(3) of the Act, any bid may be retracted or declined by the Auctioneer if not compliant with the regulations of the Consumer Protection Act.
6. The auction is not an absolute auction but subject to reserved prices settled by the sellers and as pointed out by the Auctioneer prior to the sale of the set asset or lot.
7. The auction shall take place at the date and time as advertised or publicised and will not be postponed or delayed to enable any member or group of the public to partake in the auction.
8. Should the Auctioneer become aware of any fault on advertising material or any other publication or amendment to these Rules of Auction, the Auctioneer will prior to the auction point out and when necessary amend such mistakes in the advertisement or publication.
9. Any person attending the auction to enter a bid, must prior to the auction register as a buyer on the bidders roll and comply with the conditions as set out in Chapter 1 of FICA 2001. The purchaser shall sign the bidders roll/card.
10. Any person who attends the auction to enter a bid on behalf of another person must be duly authorised thereto by means of a written letter of authority from its principal and such a person together with his principal must both register prior to the auction on the bidders roll and provide all necessary information as required in Chapter 1 of the regulations issued in terms of FICA 2001 with regard to proof of its identity. The bidders roll/card must be signed by such a person and on behalf of its principal.
11. Where the principal is a company the letters of authority shall appear on the letterhead of the company together with a certified copy of a resolution authorizing the person to bid on behalf of the company. (For purposes of this rule any reference to a company will include any reference to juristic person including partnerships, trusts or incorporated entities).
12. All purchasers have a right of inspection of all goods put up for sale and the auctioneer shall provide reasonable time and access prior to the start of the auction for such an inspection.
13. All livestock, game and goods are sold voetstoots and the purchasers do not enjoy the protection of Section 55 and 56 of the Consumer Protection Act.
14. Any information provided regarding the quality, breeding, age, date of insemination, condition, reproductive status or any information regarding health, production or mass or any other aspect of the livestock and/or game, is provided by the seller and any misrepresentation by the seller is without the cooperation or knowledge of the Auctioneer. Any right of recourse as a result of such misrepresentation shall be against the seller.
15. Any bid made does not include VAT which, where applicable, will be added to the bidding price for which a VAT invoice will be issued.
16. All sales are for cash and purchase price is payable immediately to the Auctioneer on acceptance of the bid unless otherwise arranged prior to the auction with the Auctioneer. Any payment made in cash is further subject to cash or any other handling fees. Should the Purchaser however fail to make payment within 7 days from date of delivery, BKB will be entitled to add interest calculated at the current bank prime rate plus 5% to the capital amount outstanding. The interest will be calculated monthly and capitalised.
17. Should the purchaser not pay the purchase price immediately and has failed to make arrangements for payment with the Auctioneer, then the Auctioneer can/will cancel the sale and treat the assets or lots as unsold lots which may again be presented on the auction for sale or be sold out of hand by means of liaison services, depending on the sellers mandate to the auctioneer.
18. Ownership in the lot or assets will remain that of the seller until the purchase price has been paid in full to the seller with the provision that the risk in the assets or lot passes to the purchaser at the fall of the hammer as set out in clause 23.
19. In the event that Purchaser has made necessary finance arrangements with BKB, the Purchaser hereby authorises BKB to pay the purchase price or costs of transport, insurance and any other agreed cost, minus BKBs commissions, on behalf of the Purchaser to the Seller and other service providers, in which event the said payment by BKB on behalf of the Purchaser will be deemed to be monies lent and advanced, the terms and conditions thereof being agreed with the Purchaser in a separate credit agreement or sale agreement. All payments made by BKB to the Seller on behalf of the Purchaser in terms of this clause will be made after the lapse of 5 (Five) working days from date of delivery of the asset to the Purchaser. Any payment made by BKB to the Seller prior to the lapse of the 5 (Five) working day period is made at the sole discretion of BKB and not an enforceable indulgence.
20. For as long as any amount is owing to BKB by the Purchaser, the Purchaser may not, where the assets are the subject of security of the Purchasers credit facility with BKB, relinquish possession of the said asset, nor may he cede the asset or any of its rights and obligations in terms of this agreement to a third party or otherwise encumber, sell or dispossess the said asset or allow it to become the subject of any right of retention, hypothec, pledge or any encumbrance, whatever the cause thereof may be. BKB may be entitled to cede its rights and obligations without affecting its rights of recourse for any monies still due to it.

21. In the event of the Seller already being indebted to BKB or any of its affiliates at the time of this auction, the Seller hereby irrevocably authorises BKB to set off the purchase price due to the Seller by BKB (minus BKB's commission) against the amounts due by the Seller to BKB.
22. Where BKB, in terms of a credit agreement, lent and advanced monies to the Purchaser for payment of the purchase price of any asset or payment of any transport costs or insurance premiums, no defence of whatsoever nature which the Purchaser may raise against the Seller or the transport contractor or the insurance company may be raised against BKB and the Purchaser shall still be obligated to pay all amounts owing, together with further interest and costs thereon raised in terms of the credit agreement or sale agreement, to be BKB. The conditions of this clause do not interfere with the rights, entitlements or remedies the Purchaser may have against the Seller, transport contractor or insurance company.
23. Neither the Purchaser, nor the Seller, shall be entitled to apply set-off or to retain any monies owing arising from any claim they may have against each other or BKB with regards to any amount owing in terms hereof.
24. Each lot shall immediately after the fall of the hammer deemed to be delivered to the purchaser at which time the risk will pass to the purchaser who will at his own risk and cost remove the lots or assets from the auction terrain. Removal of any assets or lots however will not be allowed by the Auctioneer until payment of the purchase price by the purchaser or acceptable arrangements for payment thereof have been made by the purchaser with the Auctioneer.
25. The Auctioneer will only be obliged to give reasons of the auction if such reasons are other than the voluntary sale of goods by its owners.
26. The bidders roll and vendor roll will be available for registered buyers for inspection with written notice and good reason during the normal office hours at the business premises of the Auctioneer.
27. The rules of auction will only be read out at the auction if they were not available to the public at the place of business of the Auctioneer. In the event of livestock and game auctions, the rules of auction remain unchanged and are in general available at the business premises of the Auctioneer or on the website of the Auctioneer.
28. Under no circumstances will BKB be held liable for any loss or damage of any cause whatsoever albeit direct or indirect damages suffered by anyone if the livestock and/or game at the auction premises have to be placed under quarantine as a result of the presence of a livestock and/or game disease present. In such event BKB will have the right to cancel the auction as well as any already complete sales and no party will be entitled or have a right of recourse against BKB.
29. Any party requiring permits, removal certificate, documentation of identification or any other statutory prescribed document will solely be responsible for obtaining same. Any instructions to an auctioneer with regards to the loading, transporting, choice of transport contractors, insurance or choice of insurers will be executed at the sole risk of the person acquiring such services and the Auctioneer will not be held responsible for any losses whether direct or indirect which may be suffered as a result of giving effect to the instructions by the Auctioneer. The Auctioneer however does accept responsibility as contemplated in Section 35(2) of the Consumer Protection Act whilst the goods or lots are under control of the auctioneer. Any agreement entered into by the Auctioneer with a transport company or insurer is done so in its representative capacity of the seller or buyer. All transport costs or insurance premiums are therefore payable to the Auctioneer in cash except if acceptable alternative arrangements were made with the Auctioneer.
30. Both the seller and the buyer consent to the jurisdiction of the Magistrates Court as contemplated in Section 45 of Act 32 of 1944 having regard to any action which the Auctioneer may institute against the buyer or seller irrespective of the cause of action. Notwithstanding the aforesaid the Auctioneer will have the sole and absolute discretion to institute action in any High Court with appropriate jurisdiction.
31. Any legal costs that BKB may have or will incur as a result of the non-compliance of the Purchaser and/or Seller in terms of its or their obligations herein, shall be recoverable by BKB, together with collection commissions from the Purchaser and/or Seller on a scale as between attorney and own client.
32. No variation, amendment, novation or addition to these terms and conditions will have the effect of BKB renouncing any of its rights in terms hereof, unless it is reduced to writing and signed by BKB.
33. No relaxation or indulgence by the Auctioneer must be interpreted as a waiver of any of the Auctioneer's rights in terms hereof. Such relaxation or indulgence must also not be interpreted as a novation hereof.
34. Should any condition be unlawful or become retrospectively unlawful, that unlawful condition shall be deemed to be amended to the extent and in the manner as is necessary to make it lawful or should such amendment be impossible, the unlawful conditions shall be deemed devisable from the remainder of the conditions and pro non scripto.

LIAISON AGREEMENT: TERMS AND CONDITIONS

- For purposes of these terms and conditions, reference to BKB will be reference to BKB Limited and/or any of its affiliate companies, including but not limited to BKB VAN WYK (Pty) Ltd and BKBLouwid (Pty) Ltd.
- All goods and/or livestock (hereinafter referred to as asset) are sold by BKB on behalf of the Seller.
- BKB is hereby appointed by the Purchaser and Seller to act for and on behalf of the Purchaser and Seller as agent in accordance with Section 54 of the Value-Added Tax Act, 1991, in respect of all tax invoices, credit and/or debit notes in respect of all livestock, game and/or goods supplied as part of the liaison agreement or any costs of transport and insurances premiums paid for on behalf of the Purchaser and Seller.
- The Seller confirms that he is the sole owner of the asset and that there are no encumbrances over the asset and the asset has not been ceded as security to a third party.
- A Seller who offers any asset for sale remains solely responsible for all representations, including misrepresentation, regarding inter alia the ages, sex and health status or any other specific aspect of the asset(s) and the Purchasers only right of recourse, should a dispute arise surrounding the representations made by the Seller, will be against the Seller.
- In all transactions, the Purchaser is entitled to inspect the asset. The purpose of the inspection is to enable the Purchaser to establish whether the asset is of the type and quality which may be reasonably expected and whether the requirements of the asset are met.
- The Purchaser must do everything in its power to attend to inspection of the asset after, either in person or by means of an agent other than an official of BKB. Should the Purchaser fail to make use of the opportunity to inspect the asset prior to delivery, the Purchaser acknowledges that he will have no right to refuse delivery of the said asset, nor have the right to return the said asset to the Seller on the grounds that the asset is not of the expected type or quality or does not meet specific requirements.
- Unless otherwise specifically agreed between the Seller and the Purchaser, the Purchaser will be entitled to delivery of the asset within a reasonable time period after entering into the transaction.
- For purposes hereof, hereof and unless specifically otherwise agreed between the Seller and Purchaser, it is deemed that the delivery takes place at the principle place of business of the Seller, at which time all the risk in the asset transfers from the Seller to the Purchaser.
- Where the asset is removed at the specific instance and request of the Purchaser by transport operators from the premises of the Seller, delivery to the Purchaser is deemed to take place at the time the asset is collected by the transport operators.
- Any transport arrangements made by an official of BKB is done so at the instance and request of the Purchaser.
- BKB is entitled to recover commissions and/or costs as specified on the counterfoil from the Purchaser and/or Seller.
- The purchase price, BKBs commissions, all statutory levies, the transport costs (if any) and the insurance costs (if any) is immediately payable in cash by the Purchaser to BKB upon entering into the transaction, unless otherwise agreed to in writing between BKB and the Purchaser. Any payment made in cash is further subject to cash or any other handling fees. Should the Purchaser however fail to make payment within 7 days from entering into the transaction, BKB will be entitled to add interest calculated at the current bank prime rate plus 5% to the capital amount outstanding. The interest will be calculated monthly and capitalised. Should the Purchaser fail to pay the purchase price within the 7 (Seven) day period and furthermore fail to make alternate finance arrangements in writing with BKB, BKB will be entitled to cancel the said sale.
- In the event that Purchaser has made necessary finance arrangements with BKB, the Purchaser hereby authorises BKB to pay the purchase price or costs of transport, insurance and any other agreed cost, minus BKBs commissions, on behalf of the Purchaser to the Seller and other service providers, in which event the said payment by BKB on behalf of the Purchaser will be deemed to be monies lent and advanced, the terms and conditions thereof being agreed with the Purchaser in a separate credit agreement or sale agreement. All payments made by BKB to the Seller on behalf of the Purchaser in terms of this clause will be made after the lapse of 5 (Five) working days from entering into the transaction. Any payment made by BKB to the Seller prior to the lapse of the 5 (Five) working day period is made at the sole discretion of BKB and not an enforceable indulgence.
- For as long as any amount is owing to BKB by the Purchaser, the Purchaser may not, where the assets are the subject of security of the Purchasers credit facility with BKB, relinquish possession of the said asset, nor may he cede the asset or any of its rights and obligations in terms of this agreement to a third party or otherwise encumber, sell or dispossess the said asset or allow it to become the subject of any right of retention, hypothec, pledge or any encumbrance, whatever the cause thereof may be. BKB may be entitled to cede its rights and obligations without affecting its rights of recourse for any monies still due to it.
- In the event of the Seller already being indebted to BKB or any of its affiliates at the time of this agreement, the Seller hereby irrevocably authorises BKB to set off the purchase price due to the Seller by BKB in terms of this agreement (minus BKBs commission) against the amounts due by the Seller to BKB.
- Where BKB, in terms of a credit agreement, lent and advanced monies to the Purchaser for payment of the purchase price of any asset or payment of any transport costs or insurance premiums, no defence of whatsoever nature which the Purchaser may raise against the Seller or the transport contractor or the insurance company may be raised against BKB and the Purchaser shall still be obligated to pay all amounts owing, together with further interest and costs thereon raised in terms of the credit agreement or sale agreement, to be BKB. The conditions of this clause do not interfere with the rights, entitlements or remedies the Purchaser may have against the Seller, transport contractor or insurance company.
- Neither the Purchaser, nor the Seller, shall be entitled to apply set-off or to retain any monies owing arising from any claim they may have against each other or BKB with regards to any amount owing in terms hereof.
- The Purchaser and Seller consent to the jurisdiction of the Magistrates Court as contemplated in terms of Section 45 of Act No 32 of 1944 in respect of any claim or action BKB may wish to institute against either the Seller or Purchaser, irrespective of the fact that the cause of action or amount of claim may exceed the jurisdiction of the Court may have in terms of Section 28 of the said legislation. Notwithstanding the above, BKB in its sole and absolute discretion, has the right to institute action against the Seller and/or Purchaser in any High Court with competent jurisdiction.
- A certificate signed by any manager, secretary or accountant for the time being of BKB and whose appointment does not have to be proven by BKB, shall be considered prima facie proof of any amount owing or payable by the Purchaser or Seller to BKB in terms of this agreement.
- Any legal costs that BKB may have or will incur as a result of the non-compliance of the Purchaser and/or Seller in terms of its or their obligations herein, shall be recoverable by BKB, together with collection commissions from the Purchaser and/or Seller on a scale as between attorney and own client.

22. This agreement constitutes the entire agreement between the parties with regards to the contents thereof and the Purchaser and Seller hereby agrees that no verbal representation or agreement varies, changes or suspends any of the terms and conditions as set out herein.
23. No variation, amendment, novation or addition to this agreement will have the effect of BKB renouncing any of its rights in terms hereof, unless it is reduced to writing and signed by BKB.
24. No concession or indulgence by BKB made to the Purchaser or Seller shall be seen as a renunciation of any of BKBs rights in terms of this agreement and the concession or indulgence shall not be interpreted as a novation of this agreement in any way.
25. In the event that any of the terms and conditions of this agreement is found to be unlawful or is made unlawful retrospectively, then such unlawful term will be deemed to have been amended to such an extent necessary to make it legitimate and if such amendment is not possible, the said terms would be deemed divorced from the remainder of the terms of this agreement and pro non scripto.
26. The Purchaser and Seller hereby respectively chooses their domicilia citandi et executandi for purposes of all notices to be the addresses as set out on the reverse side hereof.
27. This agreement in its entirety is interpreted in terms of the laws of the Republic of South Africa and all disputes, actions and other matters arising here from shall be settled in terms of such legislation.
28. When BKB issues a computer generated invoice or statement of account to the Purchaser or Seller, the terms and conditions as set out herein remain unchanged and unaffected by the issuing of such statement of account or invoice.
29. Where the Purchaser enters into a transaction as a result of direct marketing methods employed by the Seller or the Sellers agent, the Purchaser may, without penalty or reason, cancel the said transaction within 5 (Five) working days from entering into the transaction, with the understanding that all risk in the asset remains with the Purchaser until its return to the Seller.
30. It is specifically pointed out to the Purchaser that, in the event of cancellation as set out in clause 29, he remains responsible for all transport costs, any loss or change in quality of the said asset as well as a cancellation fee equal to 10% of the purchase price, which cancellation fee the parties agree is reasonable. In the event that the purchase price having already been paid to the Seller before cancellation as set out in clause 29, the Seller will be obliged to repay the purchase price to BKB, within the 15(Fifteen) working days from the date the asset has been returned to the Seller. The Seller shall be entitled to apply set-off by deducting any damages arising from losses or changes in quality. BKB shall account to the Purchaser after deduction of the cancellation fee as agreed.

#SustainabilitySynergised
PEOPLE | PLANET | PROFIT

VOORTREFLIKE DIENS

By BKB besef ons die belangrikheid van vertroue. 'n Vertroue dat die reën sal val en die grond 'n opbrengs sal lewer aan diegene wat dit bewerk. Ons weet vertroue kan nie gekoop word nie, maar word algaande verdien deur ons optrede en toewyding aan jou, in goeie en slegte tye. Ons is trots op die verhoudings wat ons oor geslagte met kliënte bou, almal gegrand op integriteit en gebind met 'n kyk in die oë en 'n stewige handdruk.

WWW.BKB.CO.ZA



Om te skandeer, laai 'n gratis QR-kode-toep af



#IntegrityIntegrated

SERVICE EXCELLENCE | ENTREPRENEURSHIP | EARNINGS | EMPLOYEES | ENVIRONMENT

AWERBUCHS

EXSTEEN'S
**D.I.Y.
SUPERSTORE**

mazars

AgriCor

BHBW
A Barloworld and BayWa company



*King Price*TM
INSURANCE

absa

MEGA
FEEDS



CAPITAUX

HINO



WILDELING



DORMER STOET



BESPROEIINGSBOERDERY



VIR MEER INLIGTING BESOEK
www.hatarifarming.co.za

